



Good Practice Guide to Hut Building

Prepared by Reforesting Scotland's Campaign for a Thousand Huts

Peter Caunt and Bernard Planterose

April 2018

www.thousandhuts.org

www.reforestingscotland.org

Acknowledgements

This Guide was authored by Peter Caunt (Quercus Rural Building Design) and Bernard Planterose (North Woods Design) on behalf of the Reforesting Scotland (RS) Thousand Huts Campaign, and with support from the RS campaign team (Karen Grant, Donald McPhillimy and Ninian Stuart). Structural input came from Lesley Donald of David Narro Associates. The Scottish Government Building Standards Division has been consulted on the Guide and has had input into various drafts to ensure that the document best supports hut builders to comply with the new legislation.

About Reforesting Scotland

Reforesting Scotland has campaigned for 25 years for a sustainable forest culture in Scotland. As well as running a range of projects, Reforesting Scotland produces a well-loved journal and hosts a popular Annual Gathering. The Thousand Huts campaign is one of Reforesting Scotland's projects. It was set up in 2011 to revive the hut movement in Scotland. RS believes hut life is good for physical and mental wellbeing, and for community life. It also is an opportunity for adults and children to develop a deeper connectedness to the natural environment and to learn skills for a more ecologically sustainable life.

Reforesting Scotland
39 Corstorphine Hill Avenue, Edinburgh, EH12 6LF
huts@reforestingscotland.org
www.thousandhuts.org
www.reforestingscotland.org

Disclaimer

Reforesting Scotland's Thousand Huts campaign has compiled this document as guidance on good practice only. It is not an authoritative statement of the law or of the policy and practice of the building standards system at the local, national or case level. It simply sets out what our contributors believe to be good practice for hut builders in complying with the Scottish Government's new regulatory framework for huts. Anyone considering undertaking a hut development should seek their own legal, planning and building regulations advice. We do not give legal advice.

We would like to thank our funders

Forestry Commission Scotland, Community Foundation Scotland, Eurban, North Woods Design, Quercus Rural Building Design and two private trusts who have asked to remain anonymous.

Introduction to this guide

This booklet helps to mark what is hoped by many to be a new era in hut building, a kind of Hutting Renaissance that in its turn is part of a much wider picture of re-connection of the people of Scotland with their land and their landscape.

The purpose of this document is to help hut builders navigate the complex range of technical issues relevant to huts which are contained within the recently updated building regulations. It is not a 'how to build it' guide, nor a guide to the planning process (planning issues are covered in the sister publication '*New hutting developments: Good practice guidance on the planning, development and management of huts and hut sites*' - available at www.thousandhuts.org).

Whilst this guide will help the hutter understand their legal requirements, and provide additional design information, the ultimate responsibility lies with the building owner to ensure their safety and

that of other hut users. If in any doubt, expert advice can and should be sought from a professional architect or structural engineer.

The new legislation brought in by the Scottish Government creates a new building type under which huts will fall. This then dictates which regulations a hut builder must follow. Within this document you will find guidance on meeting the requirements for Building Type 23A of Schedule 3 to regulation 5 of the Scottish Building Regulations. If your hut is designed and built to meet with the exceptions and conditions of Schedule 3 then a Building Warrant should not be required by the local authority for most aspects of hut construction.

However, this guide goes further than defining the minimum requirements set out above and provides additional 'Good Practice' guidance in many aspects of hut design. The difference between the mandatory requirements and additional advice are clearly marked in each Section and explained below at Section 1.3.

This guide focuses on two possible routes (or models of hut) by which to comply with the regulations: A typical post and beam hut; and a typical stud frame hut. We have had these designs analysed by structural engineers, who have advised us on the non-site-specific aspects of the structural soundness of each design. We cannot guarantee compliance of the regulations for any hut builder departing from the models set out here, and encourage hut builders to seek their own professional advice if they wish to do that.

Recent policy and legislative changes in relation to huts

The last four years have seen positive changes favouring new hut developments in Scotland, both at a policy level and in legislation. In 2014 a paragraph was added to Scottish Planning Policy encouraging planning authorities to give positive consideration to huts for recreational use. Then last year, the Scottish Government created a new building type to use as an appropriate framework for hut construction (Type 23A). This change in legislation was brought in to resolve the problem that, until recently, huts for sleeping accommodation were subject to similar building regulations as a dwelling house – causing unacceptable waste of time and money for such a small, low-impact building.

In creating this new legislation, the Government's intention was to reduce the regulatory burden on hutters, making the process cheaper and easier. In effect it also limits the burden on local authority building control officers. However, it is crucial that all hut builders realise that intrinsic to this change is the premise that hut owners hold full responsibility and liability for their building's safety and impact both on people using the hut and on the wider environment.

What the new building type means for hut builders in practice is that, as long as you comply with a set of standards and conditions (as detailed within this document), most aspects of your building will be exempt from requiring building warrants. It is important to note that although a Building Warrant will not be required for most aspects of hut construction, compliance with many key standards is MANDATORY and these are clearly marked throughout this guide. If you do not comply with the mandatory Sections of the regulations you are not eligible for exemption from building warrant. In all cases, the hut owner is legally responsible for anything that goes wrong as a result of non-compliance with these regulations.

The main aspect of construction which DOES require a Building Warrant is waste water drainage, as detailed below at Section 1.2. However, this only applies to buildings which fall within the criteria for Type 23A. If your hut does not fall within the criteria (as detailed in Section 1.2), you will require Building Warrants for other aspects of construction.

If you want to build a hut or create a site with multiple huts, you must first apply for planning permission. To help you do this, you may wish to refer to this document's sister publication for guidance, 'New hutting developments: Good practice guidance on the planning, development and management of huts and hut sites'.¹

CONTENTS

- 1 Definitions and scope of this guide
- 2 Typical timber hut - the fundamentals of good practice (**2.6 to 2.10 are MANDATORY PARTS of this SECTION**)
- 3 Siting and climate
- 4 **Structural stability (MANDATORY SECTION)**
 - (A) Foundations and substructure
 - (B) Superstructure
5. The engineered models
 - (A) Post and beam
 - (B) Stud frame
- 6 Wall cladding
- 7 Roof cladding
- 8 Decks and access (**8.2 and 8.3 are MANDATORY**)
- 9 Windows and doors
- 10 Fire strategy
- 11 Insulation and interior linings
- 12 **Stoves, flues and chimneys (MANDATORY SECTION)**
- 13 Cooking and food storage
- 14 Water and washing
- 15 Waste and composting toilets (**15.2 is a MANDATORY PART of this SECTION**)
- 16 Electrics and photovoltaics
- 17 Glossary

¹ <http://www.thousandhuts.org/wp-content/uploads/2016/02/160215-Huts-Guidance-FINAL-screen-res.pdf>

APPENDICES

- 1 POST AND BEAM HUT
- 2 STUD FRAME HUT
- 3 DECKS
- 4 OTHER USEFUL TABLES

1. DEFINITIONS and SCOPE OF THIS GUIDE

This Section will help you use this Guide, giving background on each aspect of your build and highlighting the Sections of the document where you can find more detailed information.

1.1 Planning permission - a pre-requisite

All huts will require planning permission along with permission for any associated services and access. This Guide assumes that you already have planning permission and that you will therefore have met the definition of a hut as follows (taken from the glossary of Scottish Planning Policy 2014):

- A hut is a simple building used intermittently as recreational accommodation and not as a principal residence
- It has an internal floor area of less than 30m²
- It is constructed from low impact materials
- It is generally not connected to mains water, electricity or sewerage
- It is built in such a way that it is removable with little or no trace at the end of its life

If you have not yet obtained Planning Permission you may wish to consult Reforesting Scotland's publication, '*New Hutting developments: Good practice guidance on planning, development and management of huts and hut sites*', available to download from www.thousandhuts.org.

1.2 Which part of the Building Regulations refers to huts?

Huts fall within the definition of building Type 23A. This is a new type defined only as "*a detached single-storey building used for shelter or sleeping in connection with recreation*" and buildings within this type must comply fully with the requirements of Standards 1.1, 3.17, 3.18, 3.19, 3.20, 3.21, 3.22 and 4.4 of Schedule 5 to Regulation 9.

To avoid the requirement for a Building Warrant, your hut MUST meet with the conditions and

exceptions set out in new building Type 23A of Schedule 3 of Regulation 5 of the Building (Scotland) Regulations 2004, as amended.

Type 23A also includes conditions (“exceptions”) to the above definition that would trigger a requirement for a Building Warrant. In other words, if any of the following conditions apply then you MUST apply to your local authority for a Building Warrant.

For example, if the building is:

- *A Dwelling*
- *A building having an internal floor area area exceeding 30m²*
- *A building ancillary to another building*
- *A building within 6 metres of a boundary or of another building*
- *Any wastewater disposal system serving a building of this type*
- *A building containing a gallery² or galleries unless the total gallery area occupies a space not more than (a) 8m² or (b) one half of the area of the room or space, whichever is the lesser.*

1.3 When can you gain exemption from Building Warrant, and when is a Building Warrant required?

It is the intention of this document to show how to design a hut that meets the regulations without the need for a Building Warrant, and without needing to refer to building control officers at your local authority. We have summarized the information here, however these regulations are available free on line www.scotland.gov.uk/bsd and you would be well advised to consult them for the finer detail of the regulations or if you wish to explore the wider context.

In order for your hut to comply with the regulations and gain exemption from the requirement for a Building Warrant, you must first check the list of exceptions in Section 1.2 above. If any of those conditions apply to your building you WILL have to apply for a Building Warrant before beginning construction.

If your building does NOT come under any of the exceptions listed above, you should be able to proceed without a building warrant, as long as you adhere to the guidance detailed in the MANDATORY Sections of this Guide.

The MANDATORY sections of this Guide include:

- Size (Section 2.6)
- Separation from boundaries (Section 2.7)
- Wastewater disposal (Section 2.8)
- Galleries or platforms (Section 2.9)
- Pedestrian protective barriers (Section 2.10)
- Structural stability (Section 4)
- Stoves, flues and chimneys (Section 12)
- Waste and composting toilets (Section 15)

Remember that some aspects of hut construction are NOT exempt from the requirement for Building Warrant under any circumstance. One such aspect is wastewater disposal. So, for example, if you wanted to put a flushing toilet in a hut, that aspect of the construction would always require a Building Warrant. Other exceptions are detailed in Section 1.2 above.

² For the purpose of this document, ‘gallery’ means a raised floor or platform which is open to the room or space into which it projects and is not enclosed below.

Whilst the above “Exceptions” to the Type 23A are concisely defined and should therefore be readily understood, compliance with Standards 1.1, 3.17-3.22 and 4.4 of Schedule 5 is more complicated and this guide seeks to explain in detail how this can be achieved.

In order to gain exemption from Building Warrant there are certain mandatory requirements. The mandatory Sections of this Guide are Sections 4 (structure) and 12 (fixed combustion appliances) along with parts of Section 2 (various exceptions to the exemption), parts of Section 8 (pedestrian protective barriers and height of decks off ground) and parts of Section 15 (waste water systems). You will find that they are clearly marked in the text.

1.4 Structural stability and engineering

A basic principle is that all buildings and structures should be safe for their inhabitants and regular users as well as the general public. Designers, builders and landowners on whose land these structures stand all have significant legal responsibilities in this regard.

In order to satisfy the building regulation requirements of Type 23A for structural stability (ie to meet building standard 1.1), either of the two following good practice options may be followed:

- 1) You may choose to follow one of the engineered models in Section 5 (and Appendices 1 and 2) in this Guide exactly - there is still plenty of scope for individuality in the choice of form, finishes and materials, fenestration, services and systems, cladding etc. as is made clear from the many areas of design covered in this Guide.
- 2) You may collaborate with a structural engineer to achieve your own or your architect's hut design. Your engineer must provide you with a fully specified structural design for your hut and certificate for the design of both foundations and superstructure calculated in relation to the actual site conditions concerned. As long as you adhere to the 30 m² rule (for maximum internal floor area) and all other mandatory Sections of this Guide, you will not need to apply for a building warrant. You could use the engineered models in this Guide as a point of departure for your own design, which could reduce an engineer's input.

1.5 Fixed combustion appliances

Fixed combustion appliances include woodburning stoves, the most common heat source in Scotland's huts. There are important health and safety standards for stove installation, which are designed to protect the hut and its occupants from fire risk, as well as from carbon monoxide poisoning, and these must be observed very carefully. In order to satisfy the building regulation requirements of Type 23A for fixed combustion appliances (i.e. to meet standards 3.17 to 3.22 inclusive) your installation should conform to all the conditions set out in Section 12 of this Guide.

1.6 Pedestrian protective barriers

The new legislation includes provision for pedestrian protective barriers – in other words, railings, banisters and any type of safety barrier needed to prevent people falling off ledges in your hut. In order to satisfy the building regulation requirements of Type 23A for pedestrian barriers (ie. to meet

standard 4.4), your building and all associated access and decking arrangements should conform to the conditions set out in Section 8.2 and 8.3 of this Guide.

1.7 Types of hut covered in this Guide

A wide variety of typologies can meet the Scottish Planning Policy 2014 definition of a hut in terms of sustainability, low carbon, simplicity and ease of final deconstruction (see Section 1.1 of this Guide). However, for the majority of hutters, it is likely that their preference will be the use of timber in structure, if not also for linings and claddings. This Guide therefore deals mostly with timber as the primary building material. This so called 'timber first' design strategy is likely to fit well with use of on-site or local timber resources which should achieve very low embodied carbon buildings in line with wider Government objectives.

Claddings, linings and roof coverings other than timber are also covered where such materials work without prejudice to the underlying structure and principles detailed herein.

This Guide does NOT cover masonry, straw, earth (adobe, earthship etc,) structural insulated panel systems (SIPS) or steel building systems. Some Sections of this document will still be relevant to a hut built with such materials or systems but, to comply with the legislation, if you are using these methods you will need the services of a qualified structural engineer to certify the structure in order to meet the mandatory requirement of the 23A Exemption concerning structural stability (Standard 1.1). The structure in this context will include foundations, sub- and superstructure. It may also include any associated deck or walkway over 1.2 m above ground (for more information refer to Section 8).

This document deals with huts on an individual basis and does not deal with *hut developments* of several buildings where services will most likely be shared. It does however underline the regulation concerning minimum distance between huts and other buildings and distances to boundaries. Domestic Building Standards contain further detail concerning these critical distances in relation to waste water systems, roads, buildings and water courses.

Typology of huts

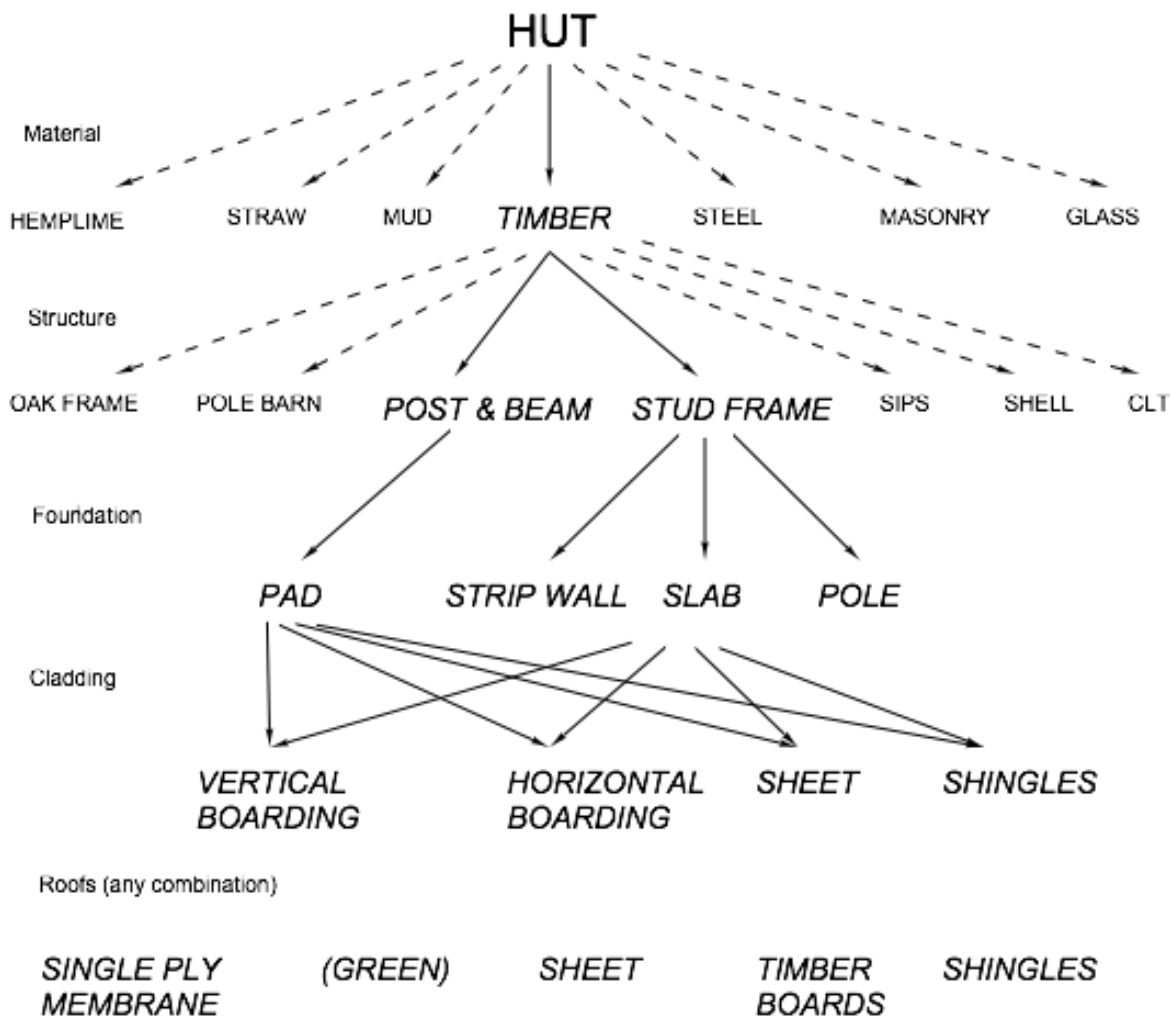

*The typical hut described in this guide is shown in italics with solid arrows
Green roofs have variable loads depending on their design so an
engineer should be involved*

1B

2. The fundamentals of good practice in hut design

This Section covers the many design aspects which influence whether your hut or hut site is a successful design which works well for hut users and minimizes the impact on the surrounding environment.

Sections 2.1 to 2.5 deal with concepts implicit in the planning policy which impact the design of a hut but are *not* part of the Regulations relating to gaining exemption from Building Warrant (i.e. they are advisory, rather than mandatory). **Sections 2.6 to 2.10 deal with regulations which *must* be observed to achieve exemption from the requirement for a Building Warrant (in other words, they are mandatory).**

2.1 Access and accessibility

The ease of access to a hut is at the discretion of the hut owner. Some huts will be intended for people with disabilities and these will be designed accordingly. They may include a suitable access path from the nearest road.

It is envisaged that to maintain the low impact of hut developments, cars will often be kept remote from the hut site itself. Sometimes the provision of ramps (see Section 8) or level thresholds to doors (see Section 9) will be easy to achieve without additional expense and these are recommended as good practice.

Timber framed huts will often be raised clear of the ground with suspended floors and there will therefore be a need for steps. Sometimes a deck or walkway from slightly higher ground can be used to eliminate this need. In these cases, the **mandatory regulations** (see Section 2.10 below) will need to be observed in relation to the height off the ground, edge protection and hand rails. (see also Section 8).

2.2 Simplicity

A hut can be little more than a camping shelter without services and without insulation, designed simply to keep out the wind and the rain. Or it could be a fully serviced, well insulated hut designed for year-round use. Wherever a hut falls on the spectrum between these extremes, it should exhibit a simplicity of form and materials and an economy of design - not least because this will enable it to fulfil the other expectations of sustainability, low embodied carbon and de-constructibility. Simple does not necessarily mean traditional but there is much to recommend a simple orthogonal or rectangular floor plan and a constant short cross section.

2.3 Low carbon and low impact

When designing your hut in compliance with Scottish Planning Policy, you will want to ensure your hut is as low impact as possible. The term 'low impact' is used to refer to developments which have little or no negative impact on the surrounding ecosystems, other natural systems (such as the water or atmospheric systems), or human activity and enjoyment of the area. The term can also be interpreted in the context of the Scottish Government's 'low carbon' transition strategy. (*"A Low Carbon Economic Strategy for Scotland, Scottish Government, November 2010*). It also has secondary meanings in terms of minimising impact on the visual amenity of the wider community and enhancing rather than reducing the biodiversity of a site.

To meet this criterion, a hut will ideally exhibit a carbon neutral (or very nearly so) energy strategy. This may vary from no space or water heating all the way through to high levels of insulation and air tightness, combined with only on-site renewables as energy sources. Using only locally sourced firewood will play a very significant role in ensuring a low carbon strategy for many huts along with small PV and solar water panels in appropriate sites.

The strategy should also extend to the embodied energy and fixed carbon in the materials and construction methods of the hut. A 'timber first' materials strategy will go a long way to meeting both of these so long as the timber is sourced and processed reasonably locally.

Reducing concrete and heavy materials will also help because these materials have high embodied energy which means they need high energy to process and transport to site.

2.4 Off-grid (autonomous) services

It is anticipated that many huts will be too remote to make use of mains services. However, where they are nearby, these may be considered if they provide the most sustainable low carbon option with least impact on the immediate site. Many hut builders and designers may prefer to generate their own energy and water supply and to deal with the hut's own waste autonomously in order to meet more exacting sustainability criteria or specific qualities of service. For energy supplies, water provision or waste treatment the hut owner must apply high standards of sustainability and there are other regulations that must be followed (for example, SEPA and your local authority maintain wholesome water standards). For more information, see Section 14 on private water supplies, Section 15 on treatment of waste and Section 16 on electricity.

2.5 De-constructibility

The principles of de-constructibility afford ease of maintenance and recycling opportunities both during and at the end of the lifetime of a building. These principles are described in detail in the SEDA web publication Design and Detailing for Deconstruction (www.seda.uk.net/assets/files/guides/dfd.pdf) and can be considered as a further aspect of meeting a 'low impact' criterion.

Of particular relevance to the timber hut builder will be separation of components to allow individual replacement, for example: the screwing of cladding and decking boards or steel roofing sheets; the bolting of post and beam frames; the use of galvanized and stainless steel fixings to prevent rusting and difficult removal of fixings.

Where budget permits, higher quality materials will be more worthwhile to recover at the end of the building's life. Good examples are sheep's wool insulation (as opposed to mineral wool) and high quality windows and doors that have stood the test of time.

2.6 Size (MANDATORY)

Both the planning policy definition of a hut and the Exception to the Type 23A Exemptions make it clear that the internal floor area of a hut must not exceed 30m². A raised gallery or platform may increase this area slightly (see Section 2.9 below). External access and decking will also add functionality but is subject to planning permission and possibly a warrant if it is above 1.2 metres from ground level (refer to Type 19 Schedule 3 of the Building Standards technical handbooks).

2.7 Separation from boundaries and other buildings (MANDATORY)

According to the new regulations set by the Scottish Government, a hut must be at least 6 metres away from any boundary. It must also be separated from any other building (including another hut or associated sanitary facility) by at least 6 metres. Effectively, where huts are on their own legally defined plots the distance between huts will be a minimum of 12 metres. The reason for this regulation is to help ensure that fire cannot easily spread from one building to another.

2.8 Wastewater disposal (MANDATORY)

The term wastewater can refer to 'black' or 'grey' water. The term 'black water' means water which has come in contact with fecal matter (i.e. toilet flushing) and the term 'grey water' refers to water which has not come into contact with human solid waste, but may have been used for cooking, bathing, washing or cleaning. You can keep chemical contamination in grey water to a minimum by using ecologically friendly soaps whenever possible.

Any part of any type of wastewater disposal system whether of 'grey' or 'black' water is subject to a Building Warrant application. On account of this it will be necessary to follow the domestic Scottish Building Standards just as you would for a dwelling. These may be found at Sections 3.7-3.9 in the Domestic Technical Handbook (www.scotland.gov/bsd) and are dealt with in this Guide at Section 15. Entirely self-contained compost or chemical toilet systems (waterless closets) do not require a building warrant and are described in Section 15.

2.9 Galleries or platforms (MANDATORY)

According to the new regulations, raised floors, galleries or sleeping platforms may extend up to half the area of the room in which they are located, or 8m², whichever is the lesser. This area can be made up of more than one platform but the aggregated area of more than one platform must not exceed the 8m² limit.

2.10 Pedestrian protective barriers (MANDATORY)

Wherever there is a difference in levels of 600mm or more, the regulations state that a protective barrier must be provided. This would apply to a sleeping platform internally as much as to an associated stair case, steps, external deck or raised access structure leading to a hut. The barrier may be made of many types of material, but it should present no opening of more than 100mm. Put another way, the barrier should be such that it would prevent the passage of a 100mm diameter sphere. However, the space between a rise in a stair and the lowest edge of a protective barrier may be larger than 100mm provided the lowest edge of the barrier is not more than 50mm above and parallel to the pitch line of the stair. The pitch line joins the leading edge of the treads in a stair (i.e. the nosings). In addition measures should be taken to discourage children from climbing the barrier, see 8.3.

The minimum heights of a protective barrier vary according to the following table. The most common situations where regulations would require a barrier will be: exterior decks and walkways which require a barrier height of 1100mm; at the edge of sleeping platforms where the required barrier height is 900mm; and along exterior steps (rising more than 600mm) where the barrier must be 840mm. All these dimensions include a handrail.

In order to meet the dynamic loads (i.e. the varying forces) imposed on a barrier, it should be designed in accordance with Building Standard EN 1991-1-1 and the associated PD 6688-1-1. It is therefore recommended to have the design of any mandatory protective barrier designed by a structural engineer and certified at the same time as the whole building structure.

Any changes in level inside and around a hut, such as stairs and ramps, should offer safe and convenient passage for the people likely to use them.

TABLE OF REQUIRED HEIGHTS OF PROTECTIVE BARRIERS
(Table 4.7 extracted from Building Standard 4.4)

| Location | Minimum height (incl handrail) |
|--|--------------------------------|
| At the edge of a floor in front of any wall, partition, fixed glazing incapable of withstanding above loadings | 800 |
| In front of an openable window if the cill is below minimum height | 800 |
| On a stair or ramp | 900 |
| At the edge of a gallery | 900 |
| Any other areas including decks | 1100 |

3. Siting and Climate

3.1 Factors affecting the siting of a hut

Several factors will influence the choice of site, orientation and form of a hut.

These include:

- Climate
- Subsoil
- Slope
- Proximity of trees
- Watercourses
- Other buildings

Site conditions vary enormously across Scotland: most obviously in the average wind strength, temperature, rainfall, snowfall and sunshine hours. However it is important to appreciate that all these factors also vary locally due to differences in topography, altitude, vegetation type and existing buildings. The soil conditions also vary considerably, ranging from solid rock to fluid sands, alluvial and glacial deposits.

You should therefore first assess your site carefully. Good practice would be to seek advice from suitably experienced builders and designers if at all possible. You will be using the services of a

structural engineer if you are departing from the models in this Guide in any case, and he or she can help with all aspects of design and siting if you ask early enough in your process.

Even if you are using one of the models in this Guide you are still advised to seek professional advice (architect, engineer or surveyor) in relation to site factors and how they affect both your foundation type choice and superstructure design.

3.2 Climate

Snow, wind, altitude and shelter are all critical factors in the design of an adequate hut structure. There is data available on rainfall, wind speeds and sunshine hours as they vary across Scotland. The first and second of these combine to give a driving rain index which will affect the choice and detailing of the cladding. The amount of sunshine and the path of the sun across the sky will affect the size and positioning of windows allowing useful passive solar gain and possibly dictate summer shading.

Follow the flow chart in figure 3A accompanied by wind map figure 3B and snow map 3C (below) to see if your site factors are challenging enough that you need to consult a structural engineer. If your site factors do not present these challenges you can proceed to Section 5 and Appendices 1 and 2 to find a suitable structure without further climatic advice.

3.3 Subsoil

As with climate, soil type has important structural implications and will be taken into account by an engineer if you are employing one in the design of your hut. The hut foundations must rest upon natural ground comprising one of the following soil types:

- Sound Rock
- Compact gravel or sand
- Stiff or firm clay or sandy clay

This guide does not cover ground conditions where fill material, peat or highly weathered rock is present. Engineering advice must be sought in these cases. If you are at all uncertain about what soil type your site exhibits, seek professional help.

Preliminary information on soil and rock types at your site can viewed on the British Geological Survey map website. Use the Geology key to find the types.

<http://mapapps.bgs.ac.uk/geologyofbritain/home.html>

Mining activity should also be checked. If your site is in an area where a coal mining report is recommended you should seek engineering advice.

<http://mapapps2.bgs.ac.uk/coalauthority/home.html>

3.4 Bearing Capacity

There are simple ways to assess the ground bearing capacity of your subsoil by digging and examining a trial pit. Hand digging or a mini excavator can be used, but you must be certain that there are no underground services that might be damaged if you use an excavator. Record the different types of soil you can see in the pit, and the difficulty or otherwise of excavating, and test with wooden peg or fingers. Note also if water is present in the pit as this will have an effect on the foundations.

In most soil types it is safe to hand dig a pit up to 1m deep. A typical size on plan is 600 mm x 600

mm. Allow a batter on the side (i.e. ensure the wall of the pit has an inward slope to support it) if the soil is particularly unstable.

The table below, based on Building Standard 8103-1:2011, shows typical observations to help identify soil types. Many soils are a mixture of gravel, sand, silt and clay and exact identification is not critical. The difference in all these terms is one of decreasing grain size, below what can be seen with the naked eye for the last two in the list. Larger stones (boulders or cobbles) can also be present. The important factor is to identify the condition shown in **bold**. The looser or softer materials may still be suitable for the foundations, but engineering design would be required to ensure structural soundness.

| Ground type | Observations in trial pit | Foundations |
|--|--|----------------------------|
| Hard Rock | Requires pneumatic or mechanical pick for excavation. | As this guide |
| Compact Gravel or Sand | Requires pick for excavation. Wooden peg 50 mm square hard to drive more than 150 mm | As this guide |
| Stiff Clay or Sandy clay | Cannot be moulded in the fingers. Requires pick for excavation. Can be indented slightly by thumb. | As this guide |
| Firm Clay or Sandy Clay | Can be moulded with substantial pressure with the fingers and excavated with a spade. Thumb makes impression easily. | As this guide |
| Loose Sand, Silty sand or Clayey sand | Dry lumps may stick together but can be easily broken up in fingers. Readily excavated with spade. 50 mm peg can be easily driven. | Specialist advice required |
| Soft Silt, Clay, Sandy Clay or Silty clay | Easily moulded in the fingers and readily excavated. Finger pushed in up to 10mm. | Specialist advice required |
| Very soft Silt, Clay Sandy clay or Silty clay | Exudes between fingers when squeezed in fist. Finger easily pushed in up to 25mm. | Specialist advice required |

3.5 Slopes

Huts can sit on flat ground or sloping ground, even on significant gradients if substructure is professionally engineered. To lessen a hut's environmental impact and the cost of reinstatement when the hut is removed, the temptation to flatten the site with an excavator should be resisted. Instead a foundation type that can cope with the natural land forms is preferred. Unless a stepped section is chosen, there could be quite a high undercroft and care should be taken to ensure this under-building structure is adequately braced (see Section 4A). The orientation of a slope is one important factor in how much daylight strikes a building which in turn affects the potential solar gain through well placed glazing (see Section 9).

3.6 Trees

Huts can be built in close proximity to trees but consideration must be given to their condition, the

stability of the soil they are growing in, the likelihood of wind-blow and the location of the roots. A rule of thumb is that the root system extends as far underground as the canopy overhead. A foundation system should be chosen that is compatible with the neighbouring trees. Trees can overshadow as well as shelter buildings and these effects should be managed to the hut's advantage over its lifetime.

3.7 Watercourses

The hut site should be free from erosion caused, for example, by a burn in spate. It should have a floor deck above likely levels of flood. Information available from SEPA about flood risk should be tempered with local knowledge. Areas excluded from housing development may still be suitable for huts. However you must consider potential riverbank erosion and landslip in steep areas when siting your hut.

3.8 Other buildings (MANDATORY in part)

The way a hut relates to the group it is within and how those other buildings are sited is a critical part of the design. As well as benefits of mutual shelter and shading and access to views you should refer to 2.7 above for mandatory conditions on the spacing of huts.

Climatic loading

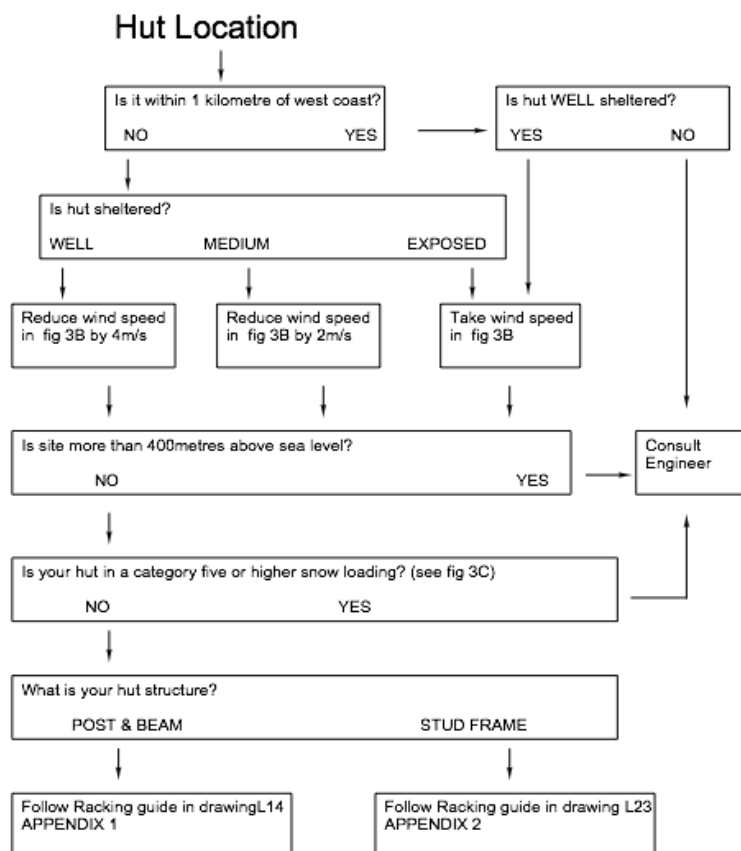

3A

Wind speed map of Scotland

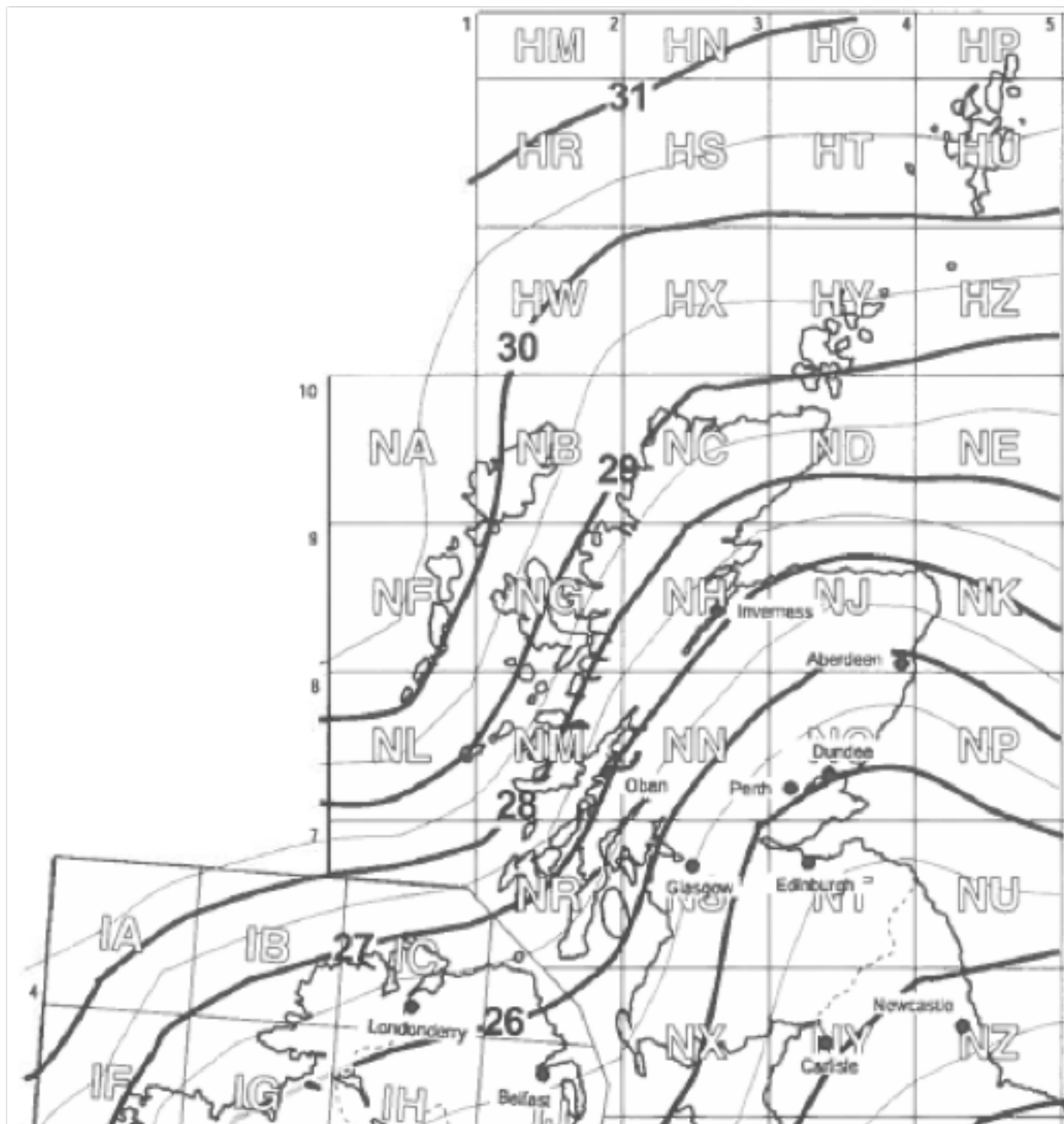

The isopleths are windspeeds in metres per second

3B

Snow map of Scotland

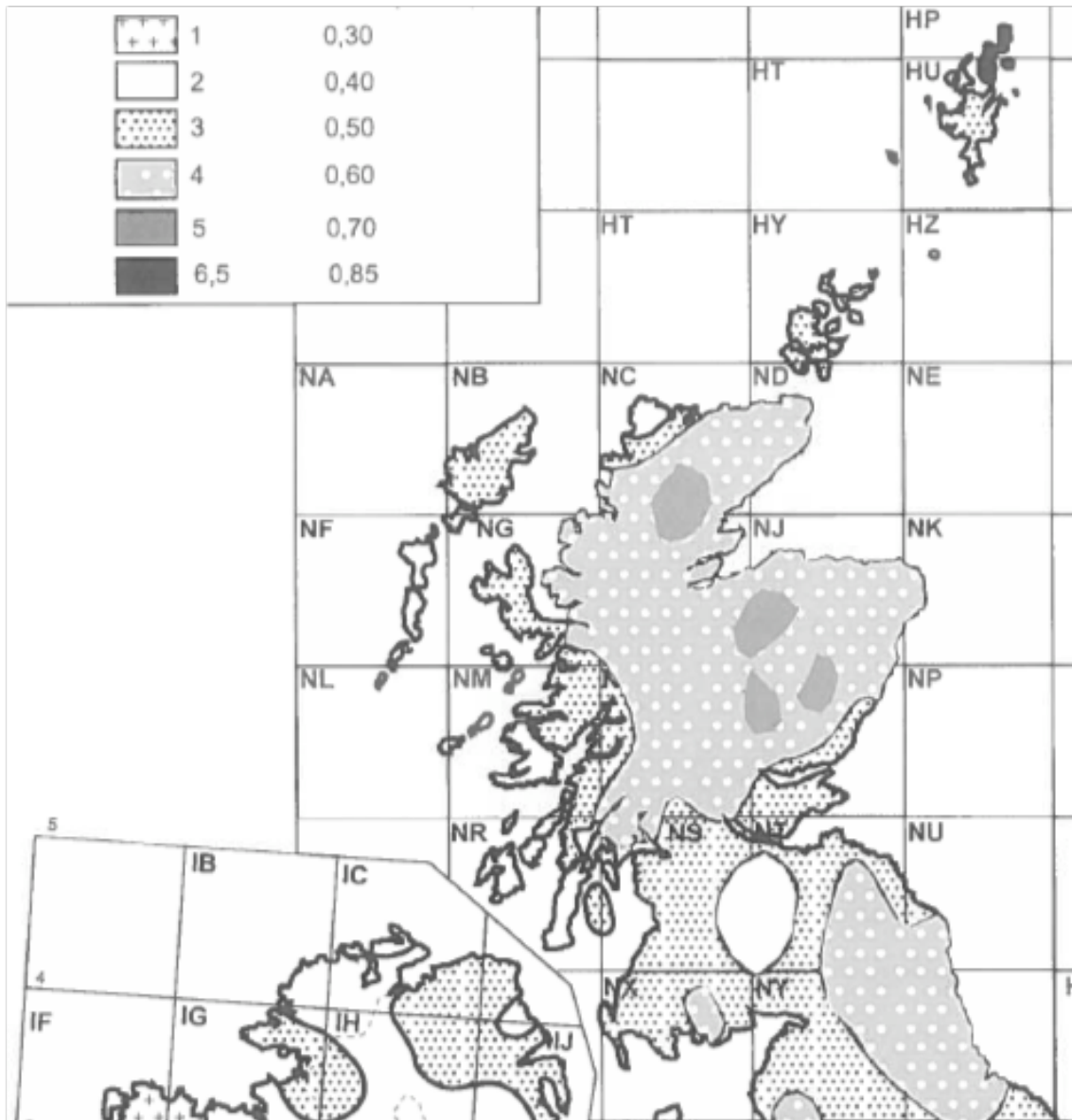

Ground snow load in kNewtons per metre squared

3C

4. STRUCTURAL STABILITY (MANDATORY)

Before reading this Section, we advise you refer back to Section 1.4 where it describes two Good Practice routes to comply with the requirements of Building Standard 1.1 of Schedule 5 (which relates to structure) and therefore to not require a Building Warrant. These routes could be summarized as:

- Using one of the engineered model huts detailed in this document (these designs have been approved in principle by our appointed structural engineers – although this cannot account for site-related factors affecting any specific development)
- Developing a different design or construction method and collaborating with a structural engineer to ensure you meet the requirements

Whichever route you choose, it is strongly advised that you seek the services of a structural engineer in order to fulfill the conditions. The purpose of this Guide is to help hutters navigate the general requirements of the new legislation, however, due to the variations on a case by case basis, the Guide cannot take the place of professional advice on any particular development. Remember that, as a hut owner, you are responsible for your own safety and that of those using your hut.

You may choose to consider proceeding without structural certification if you follow exactly the models in this Guide (see Sections 5A and B which detail models using post and beam framing and stud framing respectively). Even then you are advised to seek professional advice (architect, engineer or surveyor) as this will give you more freedom to deviate from the model and to reduce your own risks and responsibilities.

Choosing the wrong foundation type, under-sizing structural components and even using the wrong fixings for external materials can all lead to catastrophic failures endangering the lives of occupiers and the general public.

(A) Foundations and Substructure

4.1 General

This Section will help you and your engineer decide what type of foundation is appropriate to your site and superstructure design. Section 1.7 explains what types of hut this Guide deals with and what types it does not cover. Accordingly the four foundation types detailed in this Section are specifically intended for the two models detailed in this Guide or other relatively light weight, timber-framed constructions (without masonry or turf roofs) which may be designed in collaboration with a structural engineer.

4.2 Purpose of foundations

The purpose of foundations is twofold: firstly to spread the weight of the building and transfer it to the ground in such a way that the ground can resist the load without subsidence; secondly to tie the building down against wind uplift and overturning. Foundations must be robust enough to survive in the site conditions found, which may include relatively mobile sands and gravels, soft peat, running water, flooding and frost heave. They should be capable of being installed without major machinery or vehicular access. Preferably they should be removable at the end of the building's life to meet the planning definition of huts (see Section 1.1 above).

4.3 Types of foundations

Four examples follow that are suitable for the engineered model hut designs (Sections 5A and B) and for variations of these models which you may design with professional assistance. This section describes important aspects of each type that will help you decide which type is most suitable for your site conditions, hut design and available resources.

Foundation Detail - Pad

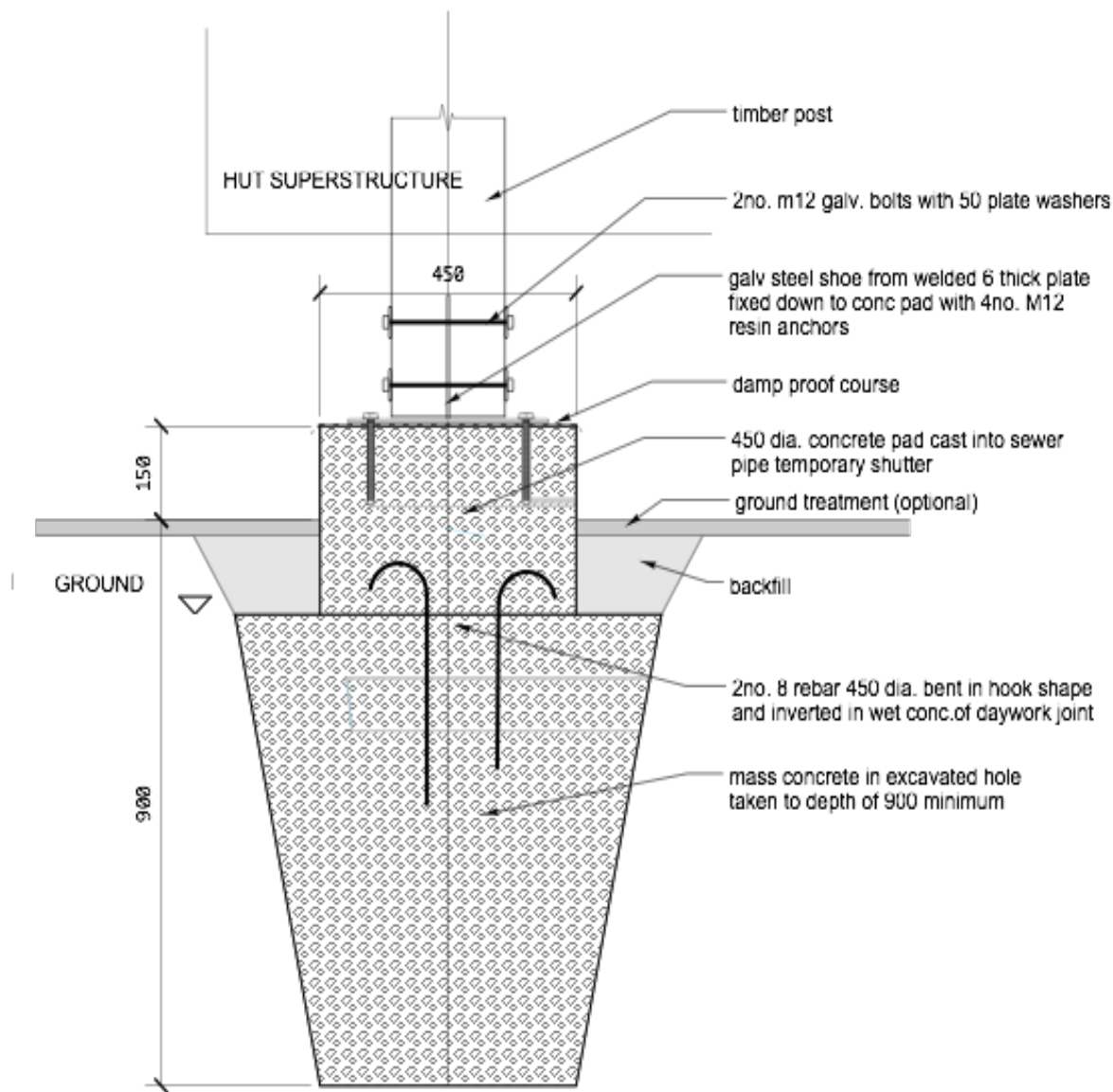

NOTES

- Suitable for post and beam superstructure
- Suitable for level or sloping sites. Post length increase to suit slope
- Where bedrock present should be taken down to sound rock
- Should be placed below every post

4A

Foundation Detail - Strip Found

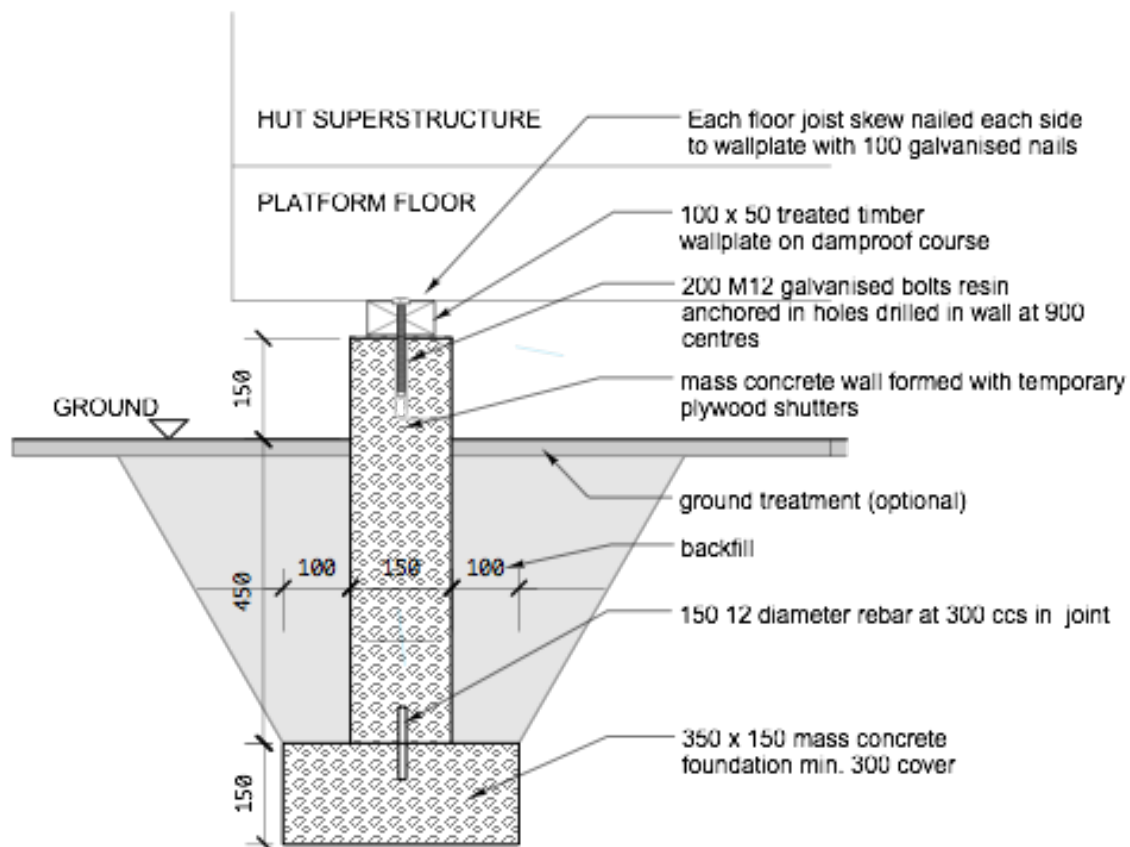

NOTES

Suitable for stud wall superstructure (see Appendix 2)

Suitable for relatively flat sites

Where bedrock present should be taken down to sound rock

Depth of cover for clay soils. Could be reduced by 150 in other soils

4B

Foundation Detail - Precast Slab

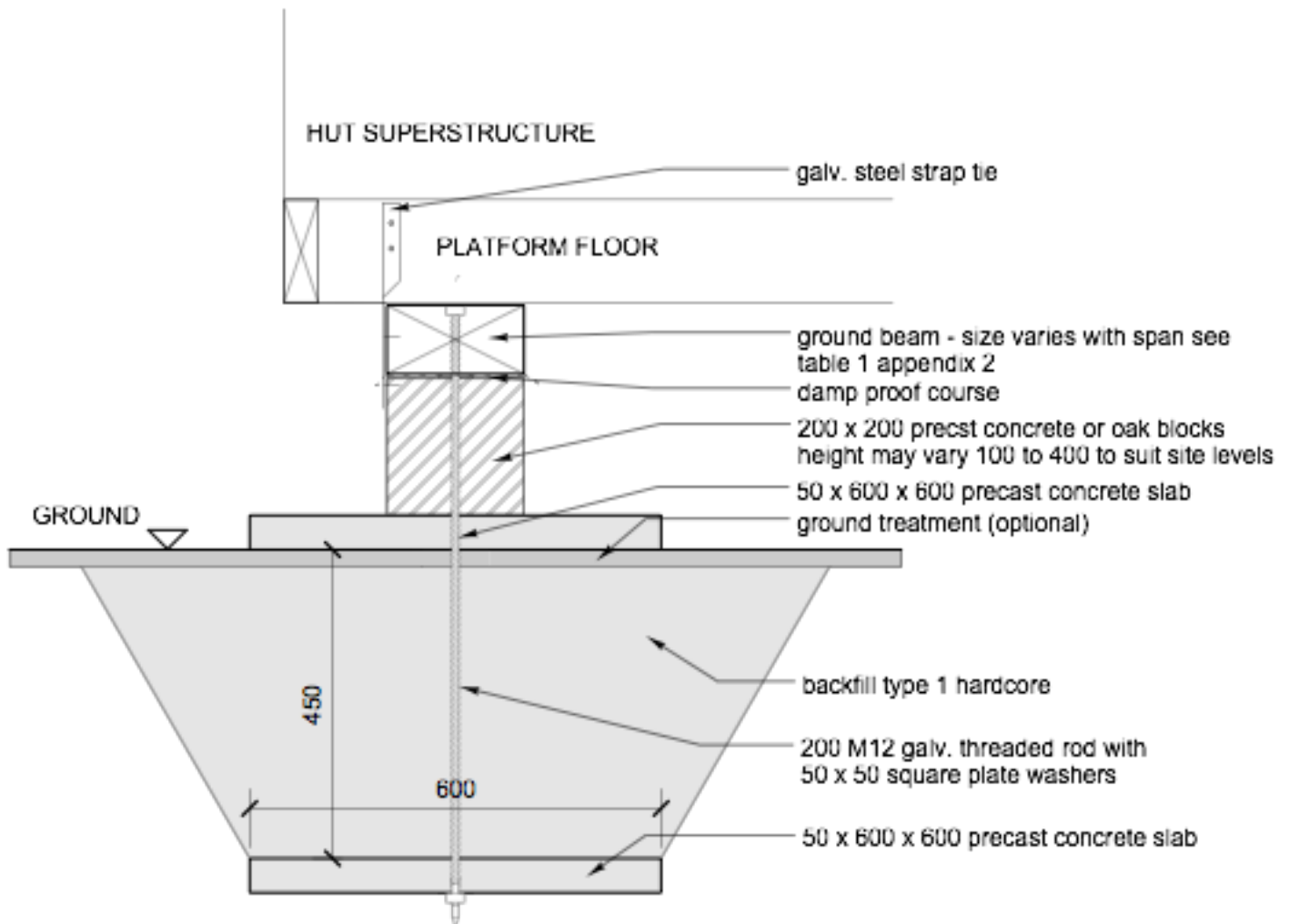

NOTES

Suitable for stud wall superstructure (see Appendix 2)

Suitable for relatively flat sites

Increase depth by 150 in clay sites

4C

Foundation Detail - Pole

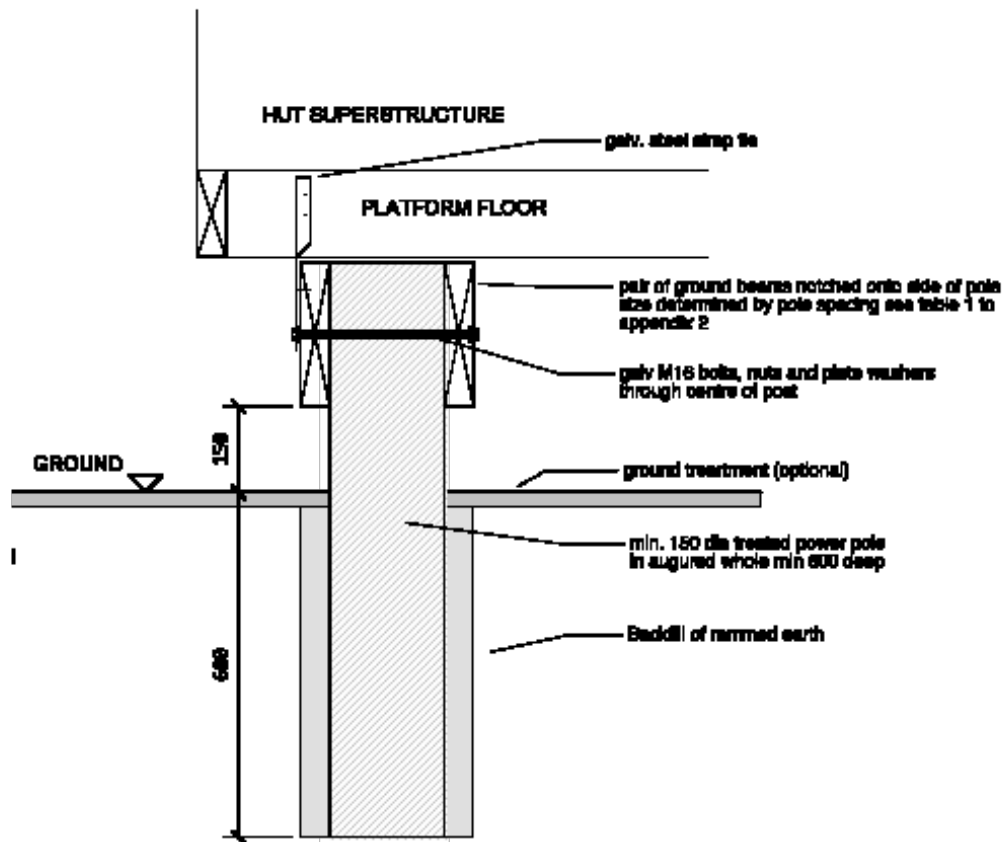

NOTES

Suitable for stud wall superstructure (see Appendix 2)
 Suitable for flat or sloping sites
 Low impact if second hand timber but can be precast concrete
 or steel driven or sugared piles

4D

4A Pad

One pad is required for each post in a post and beam building and this method is particularly suitable for sloping sites allowing different posts to be different heights according to position on

slope. Where bedrock is present the concrete will be taken down to sound rock and may be pinned to the rock with steel dowels. Pads can also be spanned by large timber ground beams that can then support stud-framed structures.

4B Strip Wall

This method is suitable for stud wall superstructure and relatively flat sites. This found comprises low poured and shuttered concrete walls on concrete trench fill. Clean to the bedrock where near surface and use trench fill to make a level base for the wall form work (shuttering). The principle can be applied using blocks or bricks to form the wall and limecrete to provide a more ecological strip found, but these alternatives have not been assessed by our structural engineer and need to be researched by the hutter

4C Precast Slab

Using readily available, standard pre-cast concrete slabs, this type is suitable for stud framed huts on relatively flat sites.

4D Pole

This method is suitable for stud framed superstructure and can accommodate sloping sites with different heights of pole. Poles can be treated telegraph poles (including recycled) or precast concrete piles, augured or dug. In true pole framing, the poles would extend up and form the superstructure of the building. The design could also be adopted for a post and beam superstructure where the pole can be accurately placed and the connection detail between post and pole is robust.

4.4 The spacing of foundations (refer to drawings Appendices 1 and 2)

The foundation plan will depend on the design of the superstructure. A strip wall foundation such as that shown in figure 4B will have two or three runs maximum 3.0 metres apart with the hut floor beams spanning between.

A pad foundation such as 4A will be located at the bottom of each of the posts in a post and beam superstructure. The Precast Slab 4C and Pole 4D foundations are also taking a point load like 4A but are designed to support a ground beam substructure to the hut onto which a timber frame is erected. They should be in a grid with a maximum spacing described in the Appendix to this Guide. (see Appendices for beam and floor joist sizing).

4.5 Tie downs - connecting foundations to superstructure (refer to drawings above)

The Post and Beam hut is bolted down to its pad foundation as shown in figure 4A. The Stud Frame hut will have one of the following options: a platform floor nailed to the wall plate as figure 4B; or with twisted ties connecting its ground beams to the foundation as shown in figure 4C; or twisted ties connected to the ground beams already bolted to the foundation in the case of figure 4D.

4.6 The use of timber in foundations and substructure (refer to drawings Appendices)

Foundations will be surmounted by a wall plate or ground beam. These must be durable or moderately durable (see 4.11 below). This is achieved by using treated softwood timber or a naturally durable timber such as the heartwood of oak or larch. The timber is normally kept out of the ground and protected from rising damp by a damp proof course (dpc). Separation from the

ground by at least 150 mm is considered necessary to avoid rain splash whilst the hut above will protect the foundation timbers from driving rain. Generous roof overhangs, well designed rainwater gear and wider claddings all help to keep foundation timbers dry. Exceptions include type 4C where oak blocks are protected below the building and type 4D where the durability of the pole is achieved by treatment.

4.7 Solum

It is not necessary to treat the solum under a hut but it may be considered desirable to remove ground vegetation, lay a membrane and cover it with stones before the hut is constructed. If animals are to be excluded from underneath the building this can be achieved by putting up a mesh screen. Any such fence or screen should be well perforated to allow a free flow of air. This is necessary to ventilate the underside of the floor and so prevent condensation.

(B) Superstructure

The term superstructure refers to the part of a building above its foundations. This Section will help you navigate the parts of this Guide that will help in your construction of the superstructure.

4.8 General points about models detailed in this guide

In Section 5 of this Guide you will find details of two structural models (with further drawings found in Appendices 1 and 2). If you follow these models you will meet Standard 1.1 of Schedule 5 of the Building Regulations (as detailed in Section 1.2) and therefore will not require a Building Warrant. If you choose to use an alternative design, the Section also gives important guidance that may be followed by your appointed engineer. **Don't forget that an alternative to the models presented herein will need to follow this Guide in all other areas that are signalled as mandatory, if exemption from Building Warrant is to be achieved.**

Section 1.7 explains what types of hut this Guide deals with and which it does not cover. The guidance given in this Section accordingly mainly deals with light weight, timber-framed structures and does not deal with a variety of other types of possible hut structure - all of which will require you to appoint a structural engineer to help design.

The two models presented in this Guide, and detailed in Section 5, have been fully engineered and represent the two principle types of timber framing that are likely to be used in hut design. They are:

- 1) Bolted timber post and beam ("timber frame construction" in USA)
- 2) Stud framed ("timber frame" in Scotland)

It should be specifically noted that this Guide does not cover (a) traditional mortise and tenon jointed post and beam structures such as associated with green oak framing in Scotland (b) stacked log systems whether natural or machined which must be fully engineered. Many cabin or hut kits of these latter types are available on the market and although they are mostly structurally robust, very few carry structural certification.

Before looking in more detail at the two structural systems in Section 5 there are two general points regarding the use of timber in construction which apply to all types of structure and which must be carefully considered: that of structural timber strength and treatment, as detailed below.

4.9 Structural timber strength

All structural timber MUST be strength graded when used in structural applications to meet the requirements of Building Type 23A and therefore to allow for Building Warrant exemption. This can be done by machine as marked on merchant timber or by visual grading by a qualified visual strength grader (available from some sawmills).

For the models described and endorsed by this Guide you require graded solid softwood timber which is easily procured from timber merchants. The grades detailed in Appendix 1 and 2 are C16 and 24 normally pine or spruce.

Home grown pine, spruce and fir visually graded to General Standard (GS) are designated C14 although larch may be designated C16. Higher Special Structural (SS) grades of timber of homegrown species may also be visually graded as follows: pine C22; spruce C18; Douglas fir C18; larch C24. Home-grown Douglas fir with cross sectional area greater than 20,000 sq mm may be graded to C24 but such sections are not used in the models in this Guide.

Hut builders attempting to use locally sourced and possibly even site-milled timber face particularly challenging decisions regarding choice of species which may in practice be determined largely by availability and cost. Douglas fir and larch will be favoured for durability and strength but spruce and pine are usually cheaper and more readily available. Each timber has its different aesthetic and performance qualities but, as far as this Section goes, it is the strength grade to which the timber has been graded that matters, and so long as this achieves C16 or C24 then it can be used for structure.

Purchased from a merchant, structurally graded timber will generally be kiln dried (KD) but locally or site milled timber is unlikely to be. Timber does not attain its full structural strength until dried and should not therefore be structurally graded or used in structural components until it reaches an average moisture content of less than 20% with no single reading greater than 24%. Note that timber more than 100mm thick cannot be visually strength graded and often has to be used with a higher moisture content, eg. in the posts of post and beam framing and in log building.

4.10 Structural timber treatment

(More on timber treatment including for non-structural elements can be found in Section 6)

Where structure is of a durable timber such as heartwood of larch or oak and/or well ventilated it will not need further treatment. Where enclosed in an insulated wall of a non-vapour permeable type (see Section 11 figure 11A) it will need to be treated. If purchased from a merchant this will present no difficulty but where site milling is taking place it presents a challenge. One solution is to use a vapour permeable wall. Although materials are more expensive for this wall/roof type they do allow use of local material where otherwise it might be very unwise.

In certain foundation types (see Section 4.3 of this Guide) timber structure is exposed to the elements and will require treatment unless built of a naturally durable species. For other species you should surface coat with a preservative followed by at least two coats of high quality paint or stain, paying special attention to saturating any end grain. Timber that is entirely internal of whatever species does not require treatment. In many types of post and beam structures, it is only a small part of the posts that protrude into the external environment below the floor. Detailing should ensure that these areas are clear of the splash zone and separated by a membrane or by lead from any part of the foundation. Preservative should also be applied regularly to such critical

exposed parts of the structure.

In the models presented here, we have been careful to separate the structural frame from the secondary roof structure. This principle is not followed in a simple, uninsulated post and beam frame where any protruding roof members should also be surface treated if not of durable timber and always detailed to ensure that none are exposed to frequent wetting.

4.11 Durability of Timber

| Table of Durability | | | |
|-----------------------------|----------------|---------------------------|---------------------|
| Species | Density | Natural Durability | Treatability |
| Accoya | 475 | 1 | not relevant |
| European Oak | 710 | 2 | not relevant |
| Imported Cedar | 370 | 2 | not relevant |
| Imported Douglas Fir | 530 | 3 | 3 |
| Siberian Larch | 610 | 3 | - |
| UK Cedar | 370 | 3 | 3 |
| UK Larch | 540 | 3-4 | 2 |
| European Redwood | 520 | 3-4 | 1 |
| UK Douglas Fir | 510 | 3-4 | 2-3 |
| Scots pine | 480 | 3-4 | 1 |
| Norway spruce | 460 | 4-5 | 3 |
| Sitka Spruce | 390 | 4-5 | 2-3 |

Durability classes: 1 = durable; 5 = not durable. Treatability: 1 = easy; 3 = difficult. This table is taken from BS-EN 350-2.

SECTION 5 – TWO SAMPLE MODELS OF HUT CONSTRUCTION

This Section shows two sample models for the construction of a hut which could comply with the new regulations around building Type 23A.

The sample models we include here are:

- A Post and Beam Engineered Model
- A Stud Framed Engineered Model

These sample huts have been designed by the authors, Peter Caunt and Bernard Planterose, and have been assessed by our structural engineers to ensure soundness, stability and safety (although this cannot account for site-related constraints).

The world of hut construction is very diverse, with many creative possibilities, materials choices, challenges and opportunities. It is not possible for this document to cover all those options, and we do not attempt to do this. Instead we have focused on two basic timber hut construction methods which have been assessed and developed in relation to the new legislation on huts and building regulations. Any prospective hut builder can choose to adopt one of these construction methods, and can follow the guidance in this document to ensure that they are complying with the Scottish Government's regulations.

5A. POST and BEAM ENGINEERED MODEL

Post & Beam Model 3D

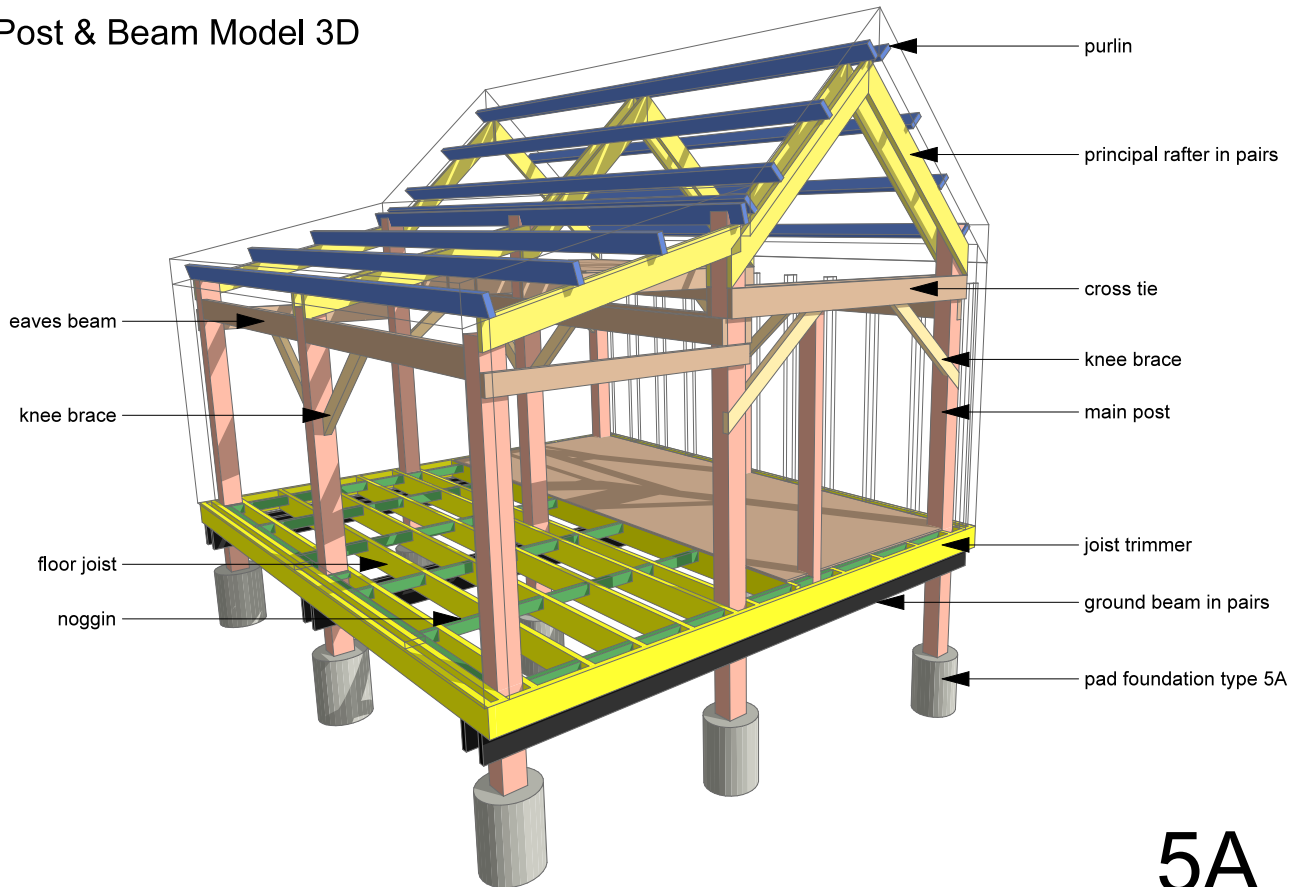

5A

Refer to drawings in appendix 1

5.1 The Post and Beam model – general introduction

Post and beam construction is one of the oldest and most globally utilised of all timber construction types. It may be chosen in hut building for a variety of reasons including:

- The physical, sculptural beauty of the frame when left exposed internally, externally or both
- The direct and readily understandable structural principles
- The pleasure and ease of using large sections of timber which may be locally sourced
- The possibility of utilising skills and craftsmanship to immediately enjoyable effect
- Its adaptation to many skill levels even to relative beginners
- Its remarkable speed
- Its particular adaptability to a small team or community approach involving frame raising for instance
- Stimulating woodland management for the ecological benefits of larger sections and longer rotations

It is particularly applicable for single-skinned (uninsulated) constructions where the frame is to be left exposed and un-compromised. It is difficult to retro-insulate a post and beam frame effectively and, if not planned from the beginning, you will lose a lot of the beauty of the frame and therefore a large part of the advantage of framing by this method.

Where a post and beam frame is to be insulated, it is most economic to utilise the insulated layer as part of the structural solution. In other words a hybrid structure is designed which will require the assistance of an experienced structural engineer to ensure soundness of construction.

5.2 Structural principles - loads

Simple hut-scaled post and beam buildings are best thought of in frames (known as bents in the USA) and bays. A one bay hut has two bents, a two bay hut has three bents and so on. See drawing L10 in Appendix 1. Frames are often made on the ground and raised by either mechanical means or by communal human strength often involving ropes and winches.

The main structural principle of post and beam buildings is that the load of the roof (both live and static loads) is transmitted entirely down the posts to the ground/foundation. The weight of the walls and any upper platform is also transmitted laterally by beams to the posts and then down through the posts to the ground. When imposed wind, snow and occupancy loads are added, we can calculate the loads imposed by each post on the ground. It is clear that the foundation must be able to take this load without subsistence or fracture. Three of the four foundation types in Section 4.3 of this Guide are designed for these loads.

5.3 Structural principles - racking and sheathing

Racking is the technical term for a wall or frame distorting under load and is dealt with by carefully designed bracing. This is usually in the form of either (a) large beams forming triangles of structure or (b) knee braces, most often at the tops of posts where they are crossed either by eaves beams (walls) or summer beams (supporting upper floor joists). It is necessary to consider racking both across the long and short axes of a building and prevent both. Racking of rafters can also take place so that roof bracing is often also required. Racking in post and beam buildings occurs when joints fail - most often due to (a) tearing or splitting of timber around bolts (b) too few or too small bolts (c) bolts too close to edge or end of timber members splitting out.

An alternative means of bracing in post and beam is to use the walls. In this case the rules pertaining to stud frames as shown in drawing L23 Appendix 2 should be followed.

5.4 Jointing and over sizing structure

As noted above (Section 4.8), traditional mortise and tenon jointed post and beam frames (like those used in green oak framing) are not covered by this Guide and will always require a structural engineer to certify. The engineered model presented here utilises simple bolts and contemporary heavy duty, self-drilling timber screws which are now readily available on the market. It is essential to follow the rules on the edge distances for drilling holes and bolting and to take care to use the specified bolt and screw sizes. Joint failure can be catastrophic.

Whilst generally against the grain of long-standing engineering principles, over-sizing of timber dimensions is advised in small-scale post and beam building. If you do not want to use and see a lot of timber then post and beam building should not be your choice! Using a lot of timber can be justified in terms of fixing a lot of carbon and making good use of a local timber resource (where there is an adequate and sustainably managed one!). It also gives more lee-way for error by amateur self-builders.

The choice of post dimension is an early and fundamental decision in post and beam design. At hut scale it will be quite normal and well advised to use large posts. Apart from the aesthetic pleasures of large section timber, large posts accommodate multiple strong beam connections more readily. The situation where two beams meet at a single post in the same plane is particularly pertinent. In order to achieve the minimum bolting dimensions (see Figure 5C, in Appendix 3) you will need a certain width of post. Whilst various beam scarfing (joining) techniques and shear pin connectors can reduce this width, it is often simplest just to start with a big post, especially where you are site milling and time rather than volume of materials is of the essence.

5.5 Steel flitch plates and shoes

The use of steel plates within joints or along whole lengths of timber is a common way of engineering post and beam timber frames but we have not considered these in this Guide due to increased costs which are not necessarily warranted at hut scale. Designed by an experienced structural engineer, steel flitch plates can however be used to almost eliminate triangulation in many structures and to confer exceptional structural integrity, larger clear spans and greater imposed loads.

Fabricated steel shoes are the preferred way of fixing the base of posts to concrete foundations. The models illustrated give an engineered design for such shoes. There are many local blacksmiths capable of making your design at low cost and they should be able to have them galvanised thus avoiding maintenance in the future.

5B. STUD FRAMED ENGINEERED MODEL

Stud Frame Model 3D

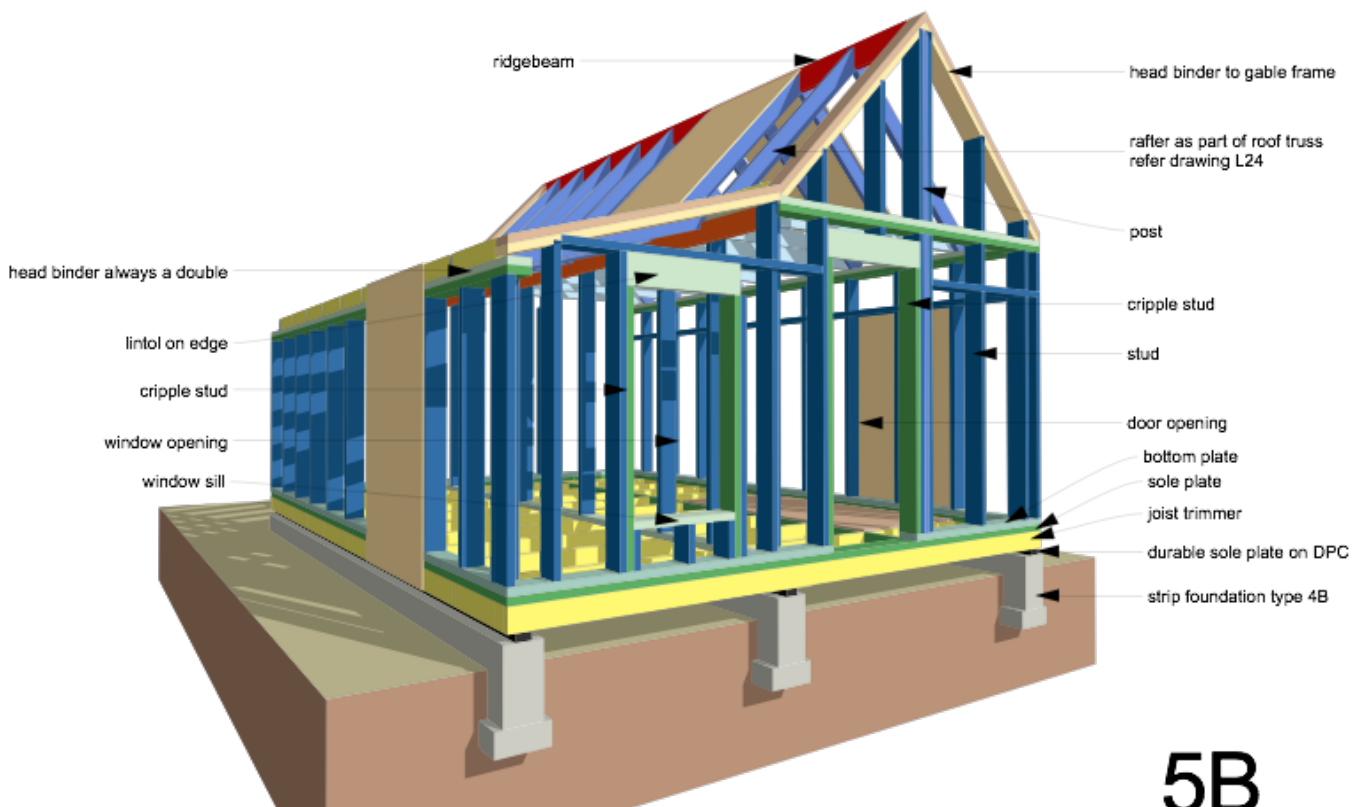

Refer to drawings in appendix 2

5.6 The stud framed model - general introduction

Stud framing is the simplest type of timber framing and, in Scotland, denotes a type of nailed (and sometimes partly screwed) framing where spacings are controlled rigorously by sheathing panel dimensions (generally 1200 x 2400 mm). This principle is applied to floors, walls and roofs. Where the frame is to be insulated, the structure will be completely concealed within a sheathed wall or roof and, in this case, the joinery can be relatively 'rough' and achieved almost entirely with a nail gun. An internally exposed stud frame, by contrast, may even be of dressed timber and very carefully jointed to present a highly finished and beautiful interior.

5.7 Structural principles - loads

In complete contrast to post and beam framing, the structural principle of the stud frame is to distribute the loads of walls, roofs and upper floors rather evenly down to a solid base/foundation through the walls. Again in contrast to post and beam which erects frames onto the foundations allowing the completion of the roof first, the sequence of construction in stud framing will involve the formation of a floor platform onto which wall frame panels are erected. Multiple rafters are then located on the wall heads joined at a ridge plate or prefabricated trusses installed.

Wall frames can be 'stick built' (piece by piece in situ) or fabricated as complete walls or sections of walls either on- or off-site. A common way is to make them on the ground within the footprint of the building and raise them into position with one side sheathed on the ground.

An alternative to the raised timber floor platform is a ground bearing slab, which is not considered by this Guide because it is not considered a low impact foundation.

5.8 Structural principles - racking and sheathing

A second principle of stud framing is that the sheathing stops the frame from racking. This racking strength is usually only conferred by one layer of sheathing on one side of the frame. Plywood, OSB and a variety of vapour permeable boards can all provide the necessary racking strength. In this Guide we use OSB and proprietary racking grade MDF. The studs laid edge on to the inner and outer sheathing give the rigidity across the plane. In the model with lean-to, the 'central' wall performs an important anti-racking function and cannot be removed without substitution of alternative structural arrangements. Such a variation will need engineering and certification.

Traditionally racking was achieved by cutting diagonal members between one pair of studs on each elevation. This method can be used in Appendix two where use of sheathing is deemed inadequate.

Voids are created which can be insulated (see Section 11 insulation). Simple gun nailing with 90 mm framing nails is appropriate but ensure that these are galvanised and intended for framing. Fixing of the sheathing to the frames would be done with 50 mm galvanised ring shank nails. Alternatively you can of course hand nail with 100 and 50 mm galvanised nails.

6. Wall Cladding

6.1 General and definitions

For the purposes of this Guide, wall and roof cladding (detailed in Section 7) is considered as a non-structural skin to protect a frame, insulated wall panel and/or inhabitants from the elements including wind and wind-driven precipitation. It is also taken to include a support system of battens and possibly counter-battens.

Cladding (and roof covering) cannot be considered entirely in isolation from structure. Choice of wall cladding type will be influenced for instance by whether there is an insulated wall behind it or not. Its design also needs to take account of the prevailing micro-climate - is it subject to frequent wind driven rain, is it deeply shaded and sheltered within a woodland?

This Guide does not cover wall constructions of either masonry or straw bale (either structural or non-structural) nor does it cover any exterior covering, rendering or cladding systems appropriate to these construction types. The Guide does cover light-weight timber and sheet material coverings. Other types of coverings will require engineering expertise. This Guide may only be followed for wall claddings, which do not exceed 6 metres in height at their highest point from the entry floor level (generally at the gable peak).

6.2 Support structures (applies to all light weight claddings with ventilation gap)

The support structure of battens and sometimes counter-battens provides a critical ventilation and drainage void in an insulated structure (see Section 11). Cladding may be fixed directly to a post and beam or stud frame in uninsulated frames but, in these cases, special care will need to be taken that water ingress is minimised which could wet the structural frame itself. Drying of this frame to prevent rotting will then be dependent on adequate ventilation of the internal space itself.

The support structure for timber cladding should be at least as durable as the cladding itself (see 6.4 below) although, at the scale of hut design, adequate longevity may be achieved by a number of different specifications.

Cladding battens are usually vacuum treated softwood or untreated larch heartwood. Surface treated softwoods are acceptable in hut building but never use non-durable softwood without some form of treatment as the void between cladding and an insulated envelope is damp and invisible.

6.3 Metal and fibre cement wall cladding

Sheet steel (or other metal) and fibre cement wall coverings are admissible and it is essential to follow the manufacturer's instructions with regard to fixing spacings and types, which vary from profile to profile. Of metal claddings, sheet steel is the most economic solution and typically each sheet covers a one metre width. Generally, sheet steel will be fixed to a timber support structure (either vertically or horizontally) with 45-65 mm self-drilling proprietary fixings with integral neoprene washers. Some profiles are best fixed in the valleys and others in the ridges. Plain galvanised is the most environmentally sound steel sheet in reducing coatings to a minimum. Coatings containing PVC are best avoided on environmental grounds and cannot be cut readily without edge damage. There is a wide range of polyester paint coatings with varying guarantees reflected in their relative costs.

Where sheet metal or fibre cement cladding is used to protect an insulated wall, it should be supported on battens to provide an adequate ventilation and drainage gap. The minimum depth of

this gap will be 20 mm. In some weather conditions condensation will occur on the back of metal in particular and must be able to run down and out of a gap at the bottom of the wall.

When carefully designed, sheet metal or fibre cement wall cladding can make a very cost effective, aesthetically pleasing and technically proficient form of external envelope. Sheet steel (formerly tin) is also a strong part of the vernacular in many parts of rural Scotland. It may be particularly appropriate with single-skinned buildings in high exposure sites to prevent leakage and subsequent frame wetting.

6.4 Timber cladding, species choice

Larch, oak and cedar (usually of Canadian origin, sometimes home-grown) are the commonest durable cladding timbers in the UK and may be used untreated. Pressure treated Scots pine (redwood) and spruce are also acceptable for hut building. Accoya and other specialist treated timbers will mostly be beyond the budget but are, of course, ideal.

In hut building it will be acceptable to use less durable timbers, monitor their performance and replace them when rotten. This will allow re-use of materials and the avoidance of toxic preservatives, which meets other hutting objectives such as low impact construction.

It is good practice to apply a hierarchy of preference when choosing timber for external applications in all timber building in Scotland. In declining order of preference :

- Modified e.g. Accoya
- Naturally durable material e.g. oak or larch (but note parts of tree have different durability)
- Pressure treated (note pine sapwood takes treatment better than spruce)
- Less durable but preservative treated and surface coated in workshop
- Less durable but preservative treated and surface coated on site

There are two other critical provisos in selecting timber.

1. The sapwood of all softwoods is non durable and will ideally be treated or coated in some way. Even naturally durable timbers contain sapwood.
2. In the case of larch, juvenile heartwood is also non durable so that careful grading/selection of heartwood is required to achieve the full durability potential of the material.

6.5 Timber cladding patterns

A large number of timber wall cladding types have been used over the centuries in different countries and may be found in the hut literature. This Guide however focuses on those that are deemed the most appropriate to the Scottish climate and the materials most readily available to the contemporary hut builder in Scotland.

The guidance that follows utilises the findings of extensive research by Napier University involving long term cladding trials and which is reported and analysed in detail in '*External Timber cladding: design, installation and performance*' - see key reference at end of this Section.

Six types of timber cladding are recommended and illustrated below (see figures 6A and 6B). Horizontal types: shiplap, weatherboarding, rainscreen. Vertical types: board on board, batten on board, gap boarding.

The use of durable timber shingles is also allowable but not illustrated. For the open rain screen cladding types you must use a proprietary waterproof and UV stabilised type membrane.

Horizontal cladding types (shown in section)



In this illustration claddings A and B are fixed directly onto the structure. See section 12 for more complex insulated structures. Cladding C is fixed on vertical battens over a membrane faced board because it is an open type.

6A

Vertical cladding types (shown in plan)

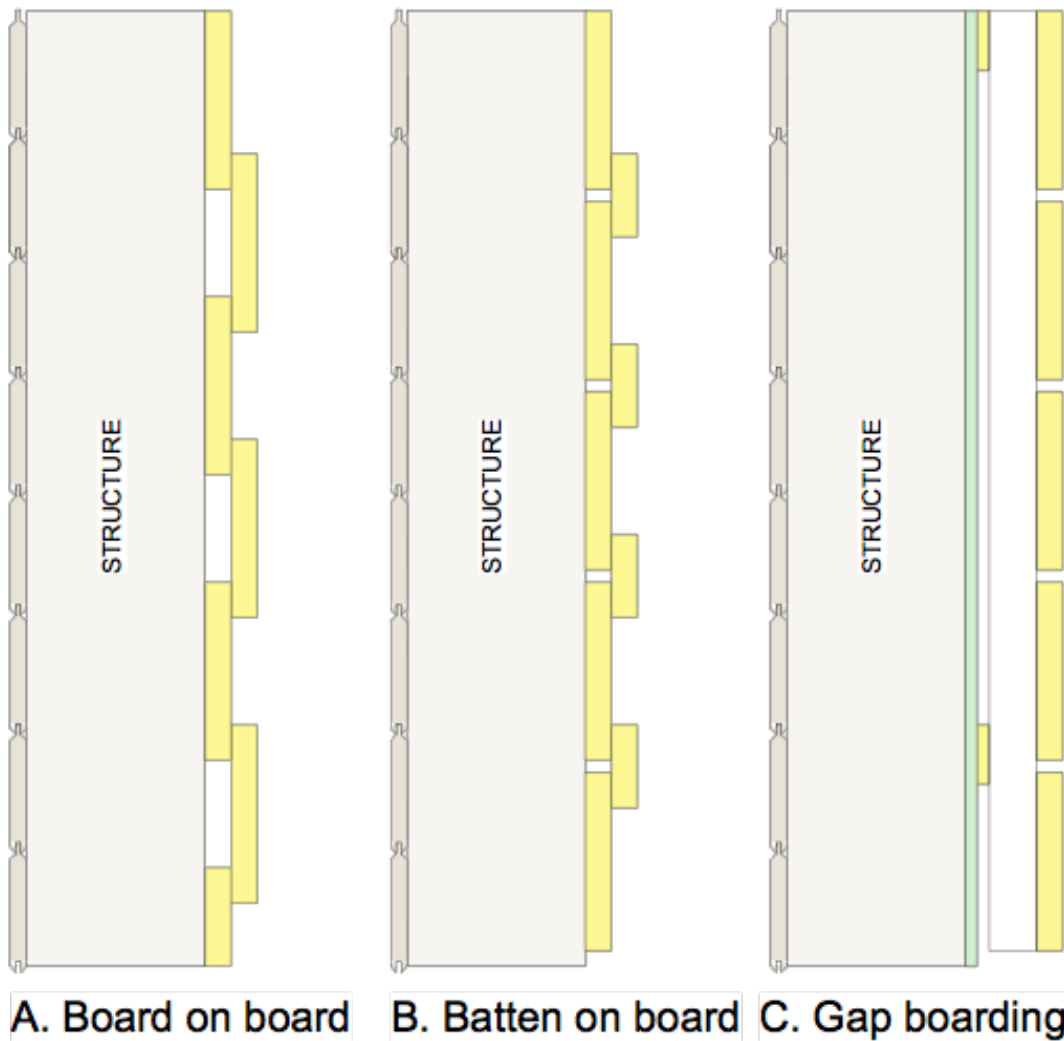

In this illustration claddings A and B are fixed directly onto the structure. See section 12 for more complex insulated structures. Cladding C is fixed on horizontal battens over a membrane faced board because it is an open type.

6B

6.6 Timber cladding detailing

There is more to designing and installing timber cladding that will last well than the inexperienced designer or builder may know. Along with the considerations addressed in Sections 6.1 to 6.5 (above), there are a number of fundamental design principles that need to be incorporated in order to achieve longevity of timber cladding as follows:

- Cavity depth should be sufficient to allow good ventilation. If wind driven precipitation is frequent, then the depth should be increased.
- Batten spacing will generally be 600 mm to coincide with timber studwork but also to provide sufficient nailing of cladding boards
- Vertical batten sections should be 19 x 45 mm minimum.
- Where horizontal battens are required (e.g for vertical timber cladding) then these should be 45 x 45 mm minimum on 600 mm centres and fixed to 38 x 19 vertical counter-battens to maintain the drainage gap of 19 mm.
- No timber cladding should be installed nearer than 150 mm from finished ground level
- Use vermin and insect meshes where appropriate especially at the base of cladding
- It is best practice never to place the end grain of timber up against solid material in a wet or damp environment. This will prevent it drying and lead to rot. Always try to leave a 2-3 mm gap between the end grain of cladding and drips, sills and flashings whether of metal, other timber or masonry.
- Timber cladding should always be able to accommodate some movement, shrinkage and swelling. Profiled boards that slot over each other must have appropriate tolerance for swelling.

6.7 Open cladding

'Open' cladding systems, sometimes known as rainscreen (see drawing 6A type C and 6B type C), are used extensively in Europe but only occasionally in Scotland, though gaining favour rapidly. In such systems, cladding boards are separated from each other and there is therefore very free airflow around them and any support system. They should only be used in combination with modern waterproof, vapour permeable, UV stabilised membranes (which may be visible behind the boards) and are clearly not usually appropriate for single skinned accommodation.

Such open cladding patterns performed relatively well in the Napier University cladding trials and can be recommended but, as with all cladding, subject to the timber either being inherently durable or the performance of less durable material enhanced by treatment and/or coating.

The support system will be frequently wetted with open cladding and should be made of timber at least as durable as the cladding itself. It is usually painted in the same colour as the cladding if a colour is being used on the latter as it will be visible as an albeit subtle pattern on the facade.

The best open cladding boards - if laid in the horizontal orientation - are trapezoidal or rhomboidal in section to promote rapid run off from the top surface of each board. The section is often relatively deep compared with closed cladding systems to confer the necessary stability. The Napier University trials also showed that vertical boards can be laid in an open pattern but this has

not been at all common in practice. It is however often used on farm buildings where ventilation without rain penetration is important. It would be appropriate for use on woodsheds which have a similar requirement.

6.8 Closed cladding

One of the simplest and therefore commonest closed cladding patterns is called board on board (batten on boards is also quite common in Scotland) and scored reasonably well in the Napier University trials. It receives recommendation in particular for windy sites but is generally a safe bet in most micro-climates and is particularly appropriate where waney edged boards are being used either to reduce processing or for their rustic appearance.

Random width boards can be used; an overlap of at least 50 mm is recommended in typically exposed sites. A relatively flush exterior face is achieved with a gap of 5-10 mm, or a more strongly patterned facade with a wider gap, see figures 6B. Such variables are partly a matter of taste and partly to do with available materials and processing capability.

Many profiled and overlapping horizontal patterns are available ranging from a simple weatherboarding to a sophisticated modern profile with expansion gaps. Only two overlapping profile types are shown in figure 6A. It is interesting to note that neither of these scored as highly as the open systems in the Napier University trials, but all are nonetheless acceptable with the above provisos on material treatments and detailing.

6.9 Fixings

Corrosion of metal fixings in wet and green timber can be significant and it will be important to use stainless steel nails or screws. Close to the sea, use marine grade stainless steel. Use proprietary ring shank cladding nails to get a good grip. These can be hand nailed or collated for nail guns. Black staining from ordinary or even galvanised nails can be both disheartening and lead to early failure. To avoid splitting, a minimum distance of 5 times the nail diameter from the edge of the wood and 10 times the diameter from the end of the wood should be adopted.

Key references

External Timber Cladding: Design, installation and performance. Ivor Davies and John Wood. Arcamedia 2010. ISBN 978-1-904320-08-1

7. Roof cladding

7.1 Metal and fibre cement sheet roofing

Metal sheet and fibre cement sheets are reliable and economic as a roof cladding as well as for wall cladding (see Section 6). The minimum pitch for sheet roofing is generally considered around 7 degrees as, the lower the pitch, the slower the run-off and risks increase of leaking fixings as well as wind driven rain between sheet joints. In practice, the latter effect can be eliminated by use of sealing strips between whole sheets running from ridge to eaves and the former by use of modern (neoprene washered) fixings that are easily inspected and replaced at hut scale. Note that the examples in Appendices one and two do not cover huts with flat or low pitch or mono-pitch roofs. It is hoped this omission will be remedied in the future.

7.2 Timber boarding and shingles

Timber boards or shingles can be used as a roof covering but there are risks attached that need to be understood and mitigated against. As with timber cladding, the main risk is decay through prolonged wetting so that choice of timber species and any treatment is particularly important. A roof will also be subject to more pronounced UV degradation and possibly stronger uplift wind forces.

The best design will be one that reduces wetting and increases speeds of drying so that steeper pitches will be preferred. All timber will need to be pressure treated or of durable species such as oak. It may be acceptable at hut scale to apply traditional Scandinavian timber roof coatings such as "Stockholm tar" or "pine tar". Contemporary modified timbers such as Accoya are used as roofing where budget permits and carry long guarantees.

Timber can be vertically orientated board on board with big overlaps - just like the wall cladding. Or horizontally overlapped just like weather-boarding on a wall.

Timber roofing may present a fire hazard where a solid fuel chimney is in use. (See Section 12)

7.3 Membranes

Roofing membranes of a wide variety of types are available ranging from traditional tar felt with and without adhered grits to single ply membranes. The common PVC membranes are losing ground to synthetic rubber (eg EPDM), which has less environmental issues. Built up felt tends to be mechanically fixed but can be torched on with the more expensive systems. Single ply membranes can be mechanically fixed but penetration of the membrane can cause leaks and glueing is often preferable. Always refer to the manufacturer's instructions.

On flat roofs ballasting (e.g. with round beach or river stones) is possible with the stones helping to hold the membrane to the deck and protecting it from UV and frost damage. However the added load will have to be accounted for by an engineer. Unballasted EPDM sheeting has the advantage of being very light and at hut scale, the whole roof, or at least one pitch, may be covered by just one sheet radically reducing the number of joints to make. Whilst DIY is possible with EPDM roofs, it is good practice to have them installed by experienced contractors.

7.4 Soil and natural materials

So called 'green' roofs, using turf or sedums are in fact largely dependent for their waterproofing on the underlay and their construction requires specialist knowledge if they are to give long and effective life.

Many proprietary underlay systems are available and if being considered by the hut designer/builder you should consult one of the many detailed guides. You can buy a number of proprietary systems with all the components supplied. If manufacturer's instructions are closely followed there is no reason why huts cannot utilise them. EPDM's at low and flat pitches (see above) can be simply ballasted. If you gain sufficient understanding there is no reason not to pursue a low cost DIY approach too.

However, it is very important to understand, that many natural materials are very heavy, especially when saturated and weight in the roof has particular structural implications which cannot be ignored. For this reason if you wish to incorporate an organic roof type you must engage the services of a structural engineer to cover that element of your hut. Also the low and mono pitch roofs most suitable for green roofs are not currently covered by the two models in this guide.

7.5 Slates and tiles

Other than lightweight felt/synthetic fabric tiles, slates and masonry tiles come into the category of heavy weight roof coverings that require the involvement of a structural engineer to ensure that the roof and load transmitting structure is adequate. Note carefully that the structurally certified models in this Guide do not include allowance for loads imposed by such roof coverings.

7.6 Rainwater

Rain can be allowed to simply fall off the edge of the roof and onto the ground from where it will resume its natural course for the site - though it is advisable to have a good roof overhang to avoid water blowing back onto wall cladding. If this approach is taken, it is also advised to provide a linear, clean stone drip area in the ground immediately below the roof edge to prevent mud splash and eventual soil erosion.

Vegetated ("green") roofs absorb, evaporate and attenuate the water flows in a similar way to ground vegetation so can help to reduce the need for artificial systems.

While a minimal approach to rainwater run-off may be adequate for a single hut in a rural setting, a group of huts could collectively create an intensity of run off that merits a drainage system. Rainwater collected in a gutter can be lead through a spout to a downpipe, which can be discharged onto the ground. At this point provision should be allowed for the water to drain away without excessive ponding or erosion. Experience will inform the hut owner whether there is a problem and he/she will be able to take action by the introduction of a very simple gravel or stone filled trench.

There is an opportunity to collect the rainwater and use it for other purposes. See Section 14.

Key references

Small Green Roofs by Nigel Dunnett, Dusty Gedge, John Little and Edmund G Snodgrass. Timber press 2011 ISBN -13: 978-1-60469-059-0

8. Decks and access (MANDATORY IN PARTS)

8.1 General

Many hut designs will incorporate decks and stairs externally and some may have internal galleries and stairs. The variety of possible designs for these structures is almost infinite but it is important to consider the structural integrity and safety aspects of each. High wind speeds and the wet climate in many parts of Scotland pose particular challenges in the construction of these useful appendages which, if not carefully designed, can become a danger to users and a maintenance nightmare.

The principles of accessibility are laid out in Section 2.1 of this Guide and should be applied on a site specific basis. In the most general terms, access routes to a hut, which include stairs, ramps or walkways, should never be less than 900 mm in width and will ideally be wider. Providing robust structures, safe surfaces and good handrails will be the most important considerations and guidance to achieve these is given below.

Whilst not a blueprint, the principles, deck and balustrades illustrated in Appendix 3 can be followed but you should seek professional advice if you have any doubts about the safety of your design.

8.2 Structural stability (MANDATORY)

A building warrant is required for any work associated with open raised external decking at a height of more than 1.2 metres

When building a deck, two aspects of structure need to be considered: (1) raised substructure (2) balustrade structure.

The structural stability of a deck is always important and you should follow the principles in figure 8A (Appendix 3). The deck illustrated in figure 8B has been engineered and you should follow the design and fixing details shown.

Where deck structures are built on sloping ground, as they often are, supporting structure can get unexpectedly tall and structural stability will become an issue. Many of the same principles as apply to post and beam framing of a building apply equally to a deck structure. It is easy to underestimate the loads that decks and especially their balustrades are subject to so always consult an engineer if in any doubt. As noted above, if the deck surface is more than 1.2 metres above the surrounding ground at any point you will need an engineer's certificate to support a mandatory Building Warrant application.

Decking boards should be a minimum of 22 mm thick (preferably 28-30mm) to span joists on 400-600 mm centres. They should be fixed to every joist with at least two proprietary decking screws or hot dipped galvanised nails.

8.3 Protective barriers to decks, walkways, galleries, ramps and stairs (MANDATORY)

Section 2.10 on Pedestrian Protective Barriers details the way in which compliance with regulation

4.4 can be achieved. This is mandatory to qualify for exemption from building warrant for your hut design. This Section repeats much of what is stated there but in the context of external access structures and arrangements.

Almost by definition, decks will be raised off the ground and the design of protective barriers at deck perimeters should follow the following specification and the balustrade design in Appendix 3

The most critical design requirements are:

- Protective barriers are required wherever the difference in height between the deck surface and the adjacent ground is more than 600 mm
- Protective barriers must be 1100 mm minimum in height for decks and level walkways
- Balustrades providing edge protection for stairs and ramps must be 840 to 1000 mm in height
- Openings in a protective barrier should prevent the passage of a 100 mm diameter sphere.
The only exception to this is at the base of a stair balustrade, which must be no more than 50 mm above and parallel to the pitch line.

In addition, measures should be taken to discourage climbing of the barrier by children. Solid horizontal rails are, for instance, relatively easy to climb whereas balusters (verticals) are not. Meshes (e.g. of wire netting) are acceptable where the 100 mm rule is met. Horizontal wires are less safe than vertical but may be acceptable where falls are not excessive.

8.4 Deck surfaces

External timber decks and stairs can become very slippery over time and the wetter the local climate, the worse the situation. A variety of deck finishes and treatments are available to reduce the risk of slips and falls. These range from profiled/grooved surfaces to inserted grips and complete gritty coatings. The choice of what measures to take to improve the grip of feet on decks will depend to some extent on the local climate, the degree of protection and the amount of maintenance and day to day care that can be given to the condition of the surface. The lowest maintenance and probably highest capital cost option is inserted non-slip grips. Decking boards can be purchased with these already inserted or they can be inserted by a joiner.

8.5 Durability and maintenance

Many of the same issues around the durability of timber decks also apply to timber cladding except that horizontal surfaces are subject to more severe u/v degradation, more wear and longer periods of wetting. Decking should therefore always be made of naturally durable timber such as larch or oak, preservative impregnated timber, acetylated or heat treated timber products. This goes for both the decking boards and the substructure. Surface coatings with high quality paints and stains incorporating preservatives will further help. Tropical hardwoods are often very durable but should be sustainably sourced (see Section 4.11). The high embodied energy of timber imported from the tropics does not make it a good choice for huts.

Ideally, fix decking boards with proprietary decking screws so that individual boards can be easily replaced if they show signs of failure. Use only galvanised bolts and exterior grade fixings for the substructure.

At the least, decks should be scrubbed or pressure washed from time to time to remove slippery algae. There is an increasing range of brush or spray applied coatings to reduce and remove algal and fungal growth and there are also some gritty coatings available.

9. Windows and Doors

9.1 Access

Whilst it is obvious that a hut will need at least one door for access, it is important in the design of small buildings to consider a door's other functions in emergency, ventilation, easy connection with associated outdoor spaces, solar gain and optimisation of views. In other words, a well-placed and specified door will provide much more than simply a point of access.

It is best practice to specify the main access door to account for as wide a range of people as possible, including wheelchair users and its clear opening width should therefore be not less than 800 mm with 300 mm of wall before any return on the opening side of the door. The threshold should not exceed 15 mm high. The door handles should be lever type and around 1100 mm from floor level. An external platt at the same level as the finished internal floor should be provided of minimum 1200 x 1200 mm. This area should be extended clear of the door swing if the door opens out.

Doors can open inwards or out and, whilst the former is more common in Britain, a door that opens out gives more space internally. As the hut will be for recreational use, the potential for using some patio door arrangement either as the access or as a second opening would help to connect inside to outside. Hinged single or double doors, sliding doors, or folding doors are all acceptable as either main or subsidiary points of access.

9.2 Ventilation

Ventilation is necessary to provide fresh air, correct humidity levels, avoid condensation and to cool the hut. It can be provided by opening windows, "French doors" and permanent ventilators in any combination. Poorly built, single skinned huts may indeed be so "leaky" as to provide adequate ventilation but it is not good practice to rely on this! A minimum ventilation requirement will be met where the opening area of windows and doors is at least 1/30th of the floor area of the hut. This is best achieved by windows capable of being opened and latched in combination with controllable slot ventilators in window frames or walls to provide background ventilation.

It is also critical to consider the additional requirement for combustion air for stoves (see Section 12) and the need for extraction of cooking smells (Section 13).

If huts are left unoccupied for more than a few days at a time then special attention should be paid to maintaining some fixed ventilation of the interior. A sufficient area of trickle ventilators in window frames or in walls becomes critical in this situation and it is important that they are left open.

9.3 Natural daylighting

In the same way that a well-placed and specified door will provide much more than simply a point of access, a well-placed window will provide a great deal more than a good view. Good daylighting plays an important part both in the visual quality of the internal environment as well as in functionality and energy conservation. Careful design of the 'fenestration' as a whole will optimise

the combination of ventilation, daylighting and solar gain for space heating (see 9.4).

Good practice will ensure that the aggregate glazed area of all windows and glazed doors should not be less than 1/15th of the floor area.

9.4 Passive solar gain

A very important function of windows, especially in otherwise unheated huts, will be to warm the hut with energy from the sun. The heat generated can be calculated, but the basic principles are to maximise southerly orientation, minimise shading and improve glazing performance (see 9.5). Concrete, natural stone or tiles in the areas where sunlight falls will store heat that can help to keep a building warm through the night. Consideration may need to be given to shading windows in the summer as overheating can also be an occasional problem in the sunniest locations.

9.5 Energy considerations

Glazing can be a significant source of heat loss (as well as gain) and this becomes more critical with an insulated hut. This guide does not set a standard for performance of windows but encourages you to consider the benefits of higher performance windows (U value of 1.6 or better). The performance of glass has been dramatically improved by use of gas-filled, double or triple glazed units with various “low E” coatings. Frames have also been greatly improved by the addition of insulation within the frame and timber frames remain the best choice for the environmentally conscious hut builder (as long as they choose certified timber only.)

But a window or door's performance is only as good as the installation and the hut builder should take great care in sealing frames to the wall structure. Proprietary expanding foams and gunned sealants are popular for this task but the environmentally sound solution is sheep's wool and air tightness tape.

9.6 Safety, escape and security

In huts, the escape door will most often be the only or main door, which should therefore have a minimum dimension of 800 x 1981 mm.

Although not mandatory, provision of a secondary means of escape should be considered which can be another door or an unobstructed openable window with area of at least 0.33 m² and a minimum of 450 mm high and 450 mm wide. The bottom of the openable area should not be more than 1100 mm above the floor. Escape windows may be appropriate to sleeping platforms in which case a safe route to the ground such as a stored rope or rope ladder may be sensible.

Glazing below 800 mm from the floor level and glazing immediately adjacent to, and within, doors must be toughened as a minimum safety requirement. Laminated glass is also suitable and is a requirement for skylights, whether opening or fixed. Both types of safety glazing must be marked with a BS kite mark, which confirms its authenticity.

It is preferable not to fit window locks as this can prevent easy opening for ventilation and escape but if they are desired, keys should be located next to the window.

To prevent heat loss at night, provide privacy and enhance security, consideration should be given to blinds, curtains and shutters. Raised platforms and galleries will provide the best privacy for sleeping and may be the warmest places in a hut.

For the safe cleaning of windows it should be possible to reach all points of the external glass whilst standing on a firm surface, safe deck or floor. This is achieved in modern windows by fully

reversible or tilt and turn mechanisms and is essential in opening roof lights. For the external cleaning of fixed glass above 4.0 metres, where safe cleaning is not possible from within the hut, you should provide ladder hooks on walls and secure masonry pads at ground level outside for ladders.

9.7 Materials and maintenance

Window and door frames can be made of timber, plastic or metal (and combinations) and this guide recommends the first of these as the material with the most suitable aesthetic, the most versatile for alteration, the easiest for DIY construction and the most environmentally sound. All the above materials are subject to oxidation of their surfaces and ensuing decay and timber frames and sills require proper maintenance if they are to last well. All the same strategies for timber choice and treatments apply to timber window and door frames as apply to timber claddings (see Section 6).

There are many opportunities for the hut builder on a restricted budget to procure second hand windows and doors, which will minimise both cost and embodied energy. It is also possible to make your own fixed windows for huts by simple framing and beading methods. If you decide to make your own window frames or external doors, you will want to choose the most durable timbers only and to treat with preservative and a high quality surface coating on the exterior to protect your investment. This guide recommends that if new windows are specified, glass is uninterrupted by astragals wherever possible to minimise leaks and heat loss.

9.8 Shape

Windows come in many shapes and sizes. Because huts will often be low cost constructions, the opportunity to use windows that are being thrown out in building alteration and demolition is very good. The hut design obviously will be steered by the windows available but the chance of free components makes the compromise worthwhile. Traditional windows are often portrait i.e. with a greater height than width. Modern designs also use small square windows, long slot windows or even whole walls of glass. The possibilities are endless.

10. Fire

10.1 Fire strategy

Every hut design should incorporate a fire strategy, which will include prevention, firefighting, escape and preparedness. There may also be input in the engineering of structure to provide some structural redundancy if desired (i.e. additional structural elements can be added so that if one part is damaged it will not collapse).

The most likely causes of fire in a hut are from solid fuel stoves and therefore Section 12 duplicates some of what follows in this Section.

10.2 Prevention

You must very carefully observe the Guidance on stove and flue installations (found in Section 12) which is **mandatory** to achieve Building Warrant Exemption. Also take great care to follow all manufacturers' instructions for installations of cookers of all types. Particularly observe the clearances of stoves and cookers to combustible materials. Where possible it is also good practice to locate cookers and stoves away from exit routes and doors.

The best preventative strategy will be to use non-combustible materials in areas of the hut which are close to sources of heat - notably stoves and cookers. Use metal and masonry shields in these areas separated from combustible materials. There are proprietary non-combustible rated boards which are also very useful in areas surrounding hot appliances, but these are beyond the scope of this Guide.

Never store gas cylinders within or under huts. They should always be stored outside the hut, not by the escape door and preferably well away from any stove or its flue. For more information on the safe use of LPG cylinders please see key reference below.

10.3 Fire fighting

You must provide adequate means to fight fire, including fire extinguishers, fire blankets, water and sand buckets. The owner or appointed responsible person should check the condition and whereabouts of all firefighting equipment at least once a year. Extinguishers should be replaced when they have expired. There should be an extinguisher both inside and outside a hut.

10.4 Escape

In huts, the escape door will most often be the only or main door, which under good practice will have a minimum dimension of 800 x 1981 mm. You may wish to consider provision of at least one other escape route in a hut besides the main door see (Section 9.6). Escape routes should be designed to extend across any decking to safe ground away from the hut.

10.5 Preparedness

While optical (smoke) alarms are effective in some fires they cannot detect invisible smoke particles generated from fast flaming fires and therefore should not be the sole detector. An optical/ionization combination with a single carbon monoxide alarm (both having a 10 year battery life) could be considered in addition to a heat alarm. They should be located as per the manufacturer's instructions. See www.fireservice.co.uk

If a combustion appliance is installed in a hut then carbon monoxide alarm must be installed to alert people to the presence of levels that may be harmful. Carbon monoxide (CO) is a colourless, odourless, and tasteless gas. It is highly toxic and dangerous to humans and animals. The gas is produced in high levels from appliances where incomplete combustion of the fuel occurs. Incomplete combustion could occur in appliance installations that are defective, lack proper maintenance or have inadequate provision for combustion air.

Instructions on how to use all firefighting equipment and what to do in a fire should be provided in all huts. This is especially important where huts are rented or used by many different parties who are unfamiliar with the hut.

Families and groups should consider a fire drill practice so that children and less able bodied people in particular know (a) the emergency route(s) they should take (b) how to open and exit from any escape windows (c) where firefighting equipment is stored and (d) how to use it.

Key Reference

UKLPG User Information Sheet 028. • <http://www.wlpga.org/wp-content/uploads/2016/09/UIS-028-Safe-Use-of-LPG-Cylinders-Revision-15-TSMT-HSE-Approved.pdf>

11. Insulation and interior linings

11.1 General

There is a fundamental difference between a single-skinned, uninsulated building and a layered, insulated one and a significant difference in cost, building time and effort. Making the right choice is essential. Rather like choosing a sleeping bag, you need to know what climatic conditions the article will have to function in. It is a serious mistake to try and extend the functionality of a two season bag into the colder months or higher exposures and it is the same with the hut envelope. Choose the right type from the outset based on the planned occupancy pattern and the local micro-climate. Whilst it is not impossible to retro-insulate, it is a relatively difficult operation to carry out well unless you have very specifically designed the wall, floor and roof structure so to do.

In the hutting literature you will see a great many huts from much warmer parts of the world than Scotland that are completely uninsulated. This approach will only be appropriate in Scotland for huts that will be used only in the warmer months. Uninsulated, exposed and mountain location huts for well-equipped hikers are often used in winter but this approach is unlikely to be a good one where occupancy is more extended.

11.2 Principles and energy

All over the world you can find uninsulated huts and bothies being heated (poorly) by solid fuel stoves. However, it is intended that hutting in Scotland should exemplify low energy, environmentally conscious design and it is therefore not good practice to install any form of heating without at least some insulation. Even locally sourced firewood has some embodied energy in the cutting (e.g by chainsaw) and it also emits some greenhouse gases during combustion.

You should therefore insulate if at all possible and, if the budget is tight, prioritise the roof over the walls and the walls over the floor. However, there is a law of diminishing returns with insulation so rather do a little of all of the envelope than a large amount in the roof and none in the floor. Eliminate draughts whether insulated or uninsulated and ventilate in a controlled manner (refer Section 9).

This Guide is not prescriptive in setting specific energy targets for huts but rather steers the hutter towards understanding the principles and making rational decisions. It would be possible to build a hut so well insulated and air tight that it did not need any heating as passive solar gain and heat from occupants would be sufficient. If a stove was wanted for cooking and comfort reasons it would be sensible to apply at least a low level of insulation and care in construction to achieve air tightness. A hut used occasionally might not justify the investment in thick insulation and the slightly higher fuel use would not be a significant carbon impact provided it was from renewable sources.

11.3 Materials

There are many types of insulation materials and the choice will be made on the basis of budget, environmental criteria, structural type and micro-climate. You may also have to consider rodent and insect threats.

Insulation should be well sealed within sheathed walls, floor and roof structures as draughts within these structures will significantly lower the performance of any insulation type. All voids should be filled. Some materials pack better than others and leave less voids. Some soft fills slump and others don't.

There are many relatively new insulating boards on the market some of which incorporate significant racking resistance. These boards are often now used to "break the thermal bridges" in timber frame construction (see 11.5).

A wide variety of foil-faced polyurethane (PUR), polyisocyanurate (PIR) and polystyrene boards are readily available and used in house construction on account of their low cost, low conductivity and light weight. However the use of this type of insulation is strongly discouraged in this Guide due to the inflammable nature of some types and the high toxicity of fumes once ignited. On no account should such materials ever be left exposed to the interior of a hut and any cavity where they have been used should be completely sealed. Due to the small volume of huts, toxic fumes generated in a fire may be of even greater consequence than in larger building types and good practice will therefore be to choose well known brands of certified non-combustible insulation.

An ecological approach to using materials is encouraged by this Guide in line with the Scottish Government low carbon and low impact definition of huts. It is allowable therefore in hut construction to use natural, recycled and waste materials for insulation such as straw, wood shavings, natural wools and scrap textiles. But remember that many of these are subject to insect attack and a fleece that at time of installation may seem perfectly adequate can become a pile of dust within a few years. Commercially available 'natural' insulations will generally be a safer option as they are treated against insect and fungal attacks.

11.4 U-values and r values

Every insulant has a thermal resistance or r value. The higher the number the better the theoretical insulation performance per unit depth. However this value does not account for thermal storage nor the way the insulation performs in reality (in relation to water vapour, slumping, vibration etc) nor how well it was installed. So beware of simplistic judgements and calculations. Take advice from a builder or architect experienced in many insulation types.

It is customary to express the insulation value of a whole construction element such as a wall, roof, window or door as a U-value. Thermal transmittance (U) equals the reciprocal of the sum of all the resistances. As well as each material in the construction, the resistance of external surfaces, internal surfaces and cavities can be added from a table. Some insulation boards and membranes, added to control moisture movement in the construction, have foil facings and these can dramatically improve U-values by reducing radiation in cavities.

Just for comparison the weighted average U values in W/m²K for a building of less than 50m², to comply with Scottish Building Standards, are 0.22 for a wall, 0.18 for a floor and 0.15 for a roof. For more detail on calculation methods see the BRE document BR 443 - '*Conventions for U-value calculations*'.

11.5 Thermal Bridging

Insulation is most effective in a continuous layer. This means however fixing through the insulation to the building. This only works with some board insulations and special fixings. Other insulants will be placed between the structural elements meaning the supports act as thermal bridges, which

more easily conduct the heat out of the building than the insulant. This effect can be calculated and reduced by designing the building to narrow the bridge or make a break in it.

In the context of simple huts, heat loss is not required to be calculated. It will be most effective to focus energy conservation on air tightness (see 11.6), a reasonable level of all round insulation and space heating that is as near carbon neutral as possible (eg from local firewood).

11.6 Air tightness

Air tightness in buildings has been afforded a high priority in recent years in order to reduce energy use and carbon emissions. Whilst it is important to eliminate unwanted draughts therefore even in a hut, it is equally important to ensure good ventilation in small spaces for human health, for moisture control and the longevity of the structure and also in order to be absolutely sure that a solid fuel stove is able to draw all the air for combustion that it requires. (Refer Section 12 stoves).

Air tightness can be achieved with various mastics and silicones but proprietary air tightness tapes are now preferred and should be applied to any junctions that may leak both on the outside of a frame and on the inside. Areas to give special attention to are around door and window frames, the floor to wall junction and the wall head to roof junction.

11.7 Condensation risks

The inhabitants of buildings give out large amounts of water vapour in their breath and also from cooking and washing. The higher the temperature in the building the more moisture it can hold in the air and a positive vapour gradient almost always exists from inside to outside in an occupied building even in the most humid external conditions.

In a confined space such as a hut, the water vapour content can become very high although this can be alleviated by good ventilation, easily achieved in small spaces by opening a window or door! However, there is still a strong tendency for water vapour to try and pass into the fabric of a building and in insulated timber-framed construction there is a risk of condensation forming within the insulated structure. This can lead to decay in the structure due most usually to fungal attack of the timber and ultimately to structural failure.

This condensation risk in the frame can be eliminated or at least considerably reduced by well-informed design and good workmanship. (Condensation risk analysis as well as U-value calculations are generally conducted at no charge by insulation manufacturers if provided with drawings of intended envelope build-ups).

There are two main design approaches to eliminate the risk of this 'interstitial' condensation. The most common is simply to try and prevent moisture passing into the wall and roof in the first place by use of a suitable vapour barrier e.g. polythene just behind the interior lining of the wall or roof. Any penetration by plumbing or electrical installations severely compromises the effectiveness of this barrier and frequent puncturing of it will cause total failure of the strategy. Therefore, such penetrations should be sealed. This approach (of a sealed wall) includes the use of preservative treated timber in the frame.

An alternative approach involves the design of a vapour permeable wall or roof, which promotes the escape of water vapour from inside the frame out to the external environment. Also known as a "breathing" wall or roof this is achieved primarily by ensuring that the inner lining (facing into the inhabited space) is relatively much more resistant to the passage of vapour than the external sheathing. The inner lining could be OSB, hardboard or plywood (with all joints well taped) while the external sheathing should be a proprietary vapour diffusive board designed for this purpose. A properly engineered vapour permeable wall does not require the frame to be treated. This may be

particularly important therefore to hut builders using home-grown and or home-processed timber. Figure 11A shows the design of a vapour permeable wall and exactly the same principles and build up can be applied to an insulated roof. In contrast figure 11B shows a conventional construction.

If you are designing a vapour permeable wall or roof, then the type of insulation used will be particularly important as it too has to allow vapour transfer readily. Sheep's wool, wood fibre and recycled newsprint insulations are all suitable in this application. Rigid synthetics, plastics and mineral wool (glass wool) should not be used in this type of wall or roof.

For further information see: BS 5252:2011 'Code of practice for control of condensation in buildings' and NHBC Foundation NF16 'A practical guide to building airtight dwellings'

Vapour transfusive construction

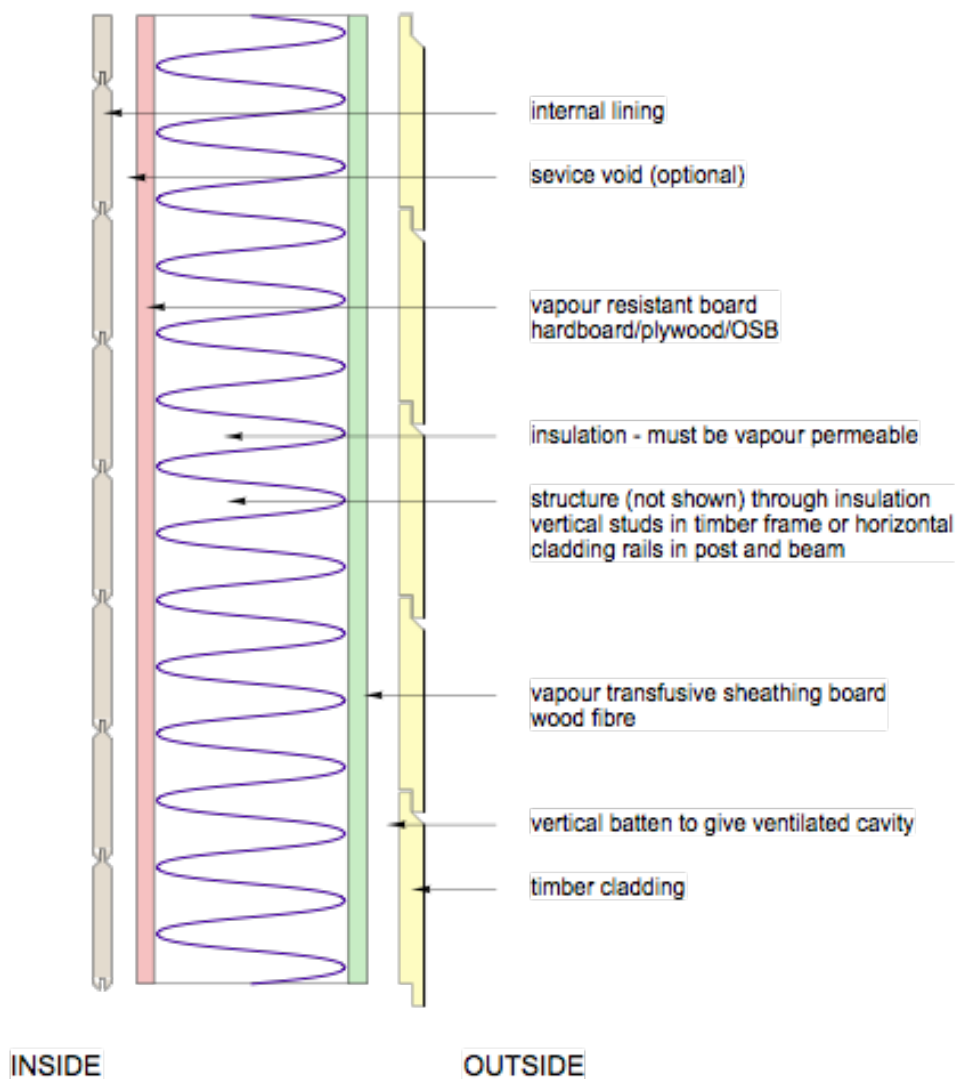

Vapour resistance of internal board is recommended to be at least five times that of the external board to avoid interstitial condensation

11A

11.8 Interior linings

Interior linings of a hut can contribute to thermal performance, vapour control and rodent control. Many huts will only be occupied for short periods and some may be left unoccupied for whole seasons. In these cases plasterboard will be a poor choice as an internal lining as it can support mould growth in a damp environment. However well detailed the building, because of their intermittent use, huts will frequently be cold and therefore require more robust materials than plasterboard. Timber linings are generally superior in all of the above respects and can take a variety of forms. OSB, fibre cement, plywood and solid timber (eg as a tongue and grooved board) are all suitable as an internal lining. Tongue and grooved boards will not keep water vapour out of a frame on their own so should be backed either by a vapour control membrane or layer of OSB/plywood. (This internal sheathing layer may be installed in any case to achieve racking resistance (see Section 5).

Surface spread of flame should be considered in general for internal lining material for walls and ceilings including any treatment thereof to restrict flame spread and its rate of growth. Where such linings are exposed to the room they should be medium risk as specified in Table 2.8 of Annex 2B of the *Domestic Technical Handbook*.

11.9 Solid timber structures

Although not covered in this guide, it is anticipated that the walls of some huts will be built with natural or machined logs or types of solid stacked interlocking timber blocks. As the material becomes more affordable, some huts of the future will even be made of laminated timber panels of one sort or another. (eg 'crosslam' or 'nail-lam') which may form complete structures of floors, walls and roofs. In all solid timber structures, the structure can double as the interior lining and, when depths reach 100 mm or more, the amount of insulation required on the outside can be quite minimal. Often a layer of rigid wood fibre is all that is needed on the external face of a solid timber construction.

The excellent hygroscopic (moisture-absorbing and releasing) and thermal storage capacities of all sorts of solid timber construction make them an ideal choice for cold and wet climates (this is not accounted for in standard Scottish heat loss calculations). It is no surprise that northern countries, where log buildings have always played a major part in domestic architecture are now focusing on laminated timber panels (eg 'crosslam'), which bring solid timber into the 21st century, combining air tightness, huge carbon fixing potential, lower embodied energy and off-site construction into one extraordinarily efficient and beautiful material.

Conventional construction

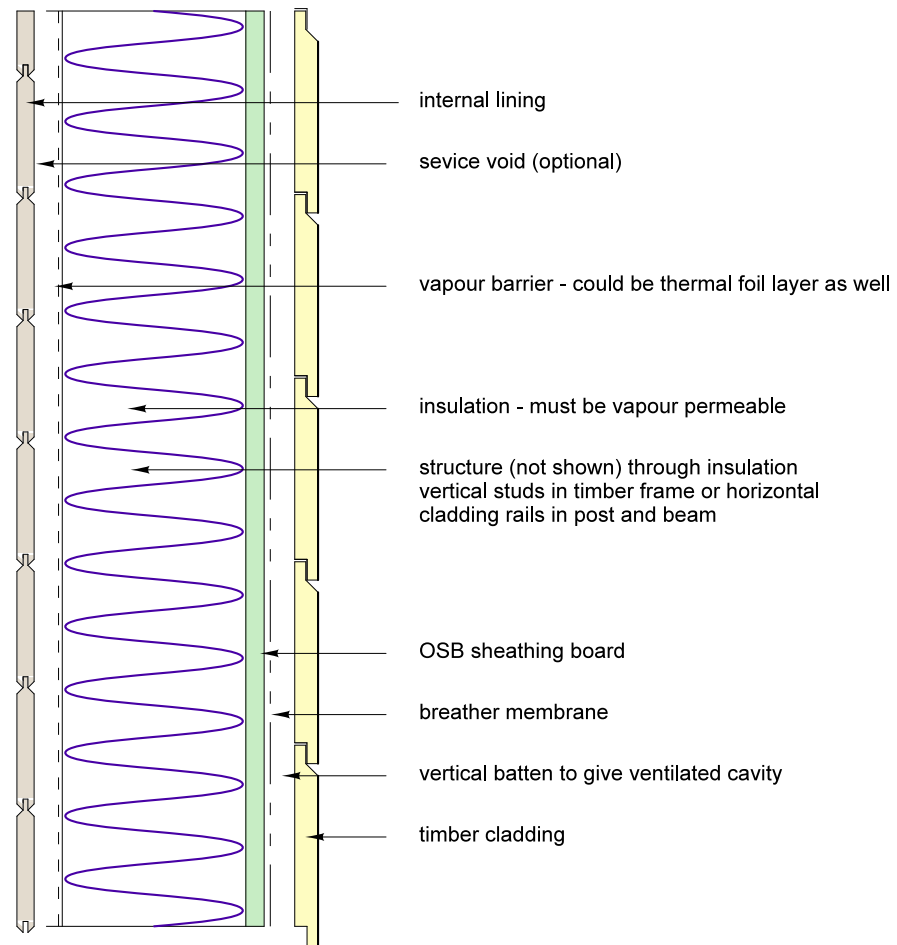

INSIDE

OUTSIDE

Vapour barrier must have all penetrations taped. Breather membrane acts as second line of defence behind the cladding

11B

12. Stoves, flues and chimneys (MANDATORY)

Solid fuel stoves will be an integral part of the majority of huts which have heating, and they also represent one of the biggest dangers to inhabitants and environment. Because of this they need to be designed and installed with the utmost care and you must conform to the Technical Guidance of the Domestic Scottish Building Standards (SBS) in its entirety to qualify for the Exemption from warrant (that is, Standards 3.17 to 3.22 inclusive).

3D of Stove Installation

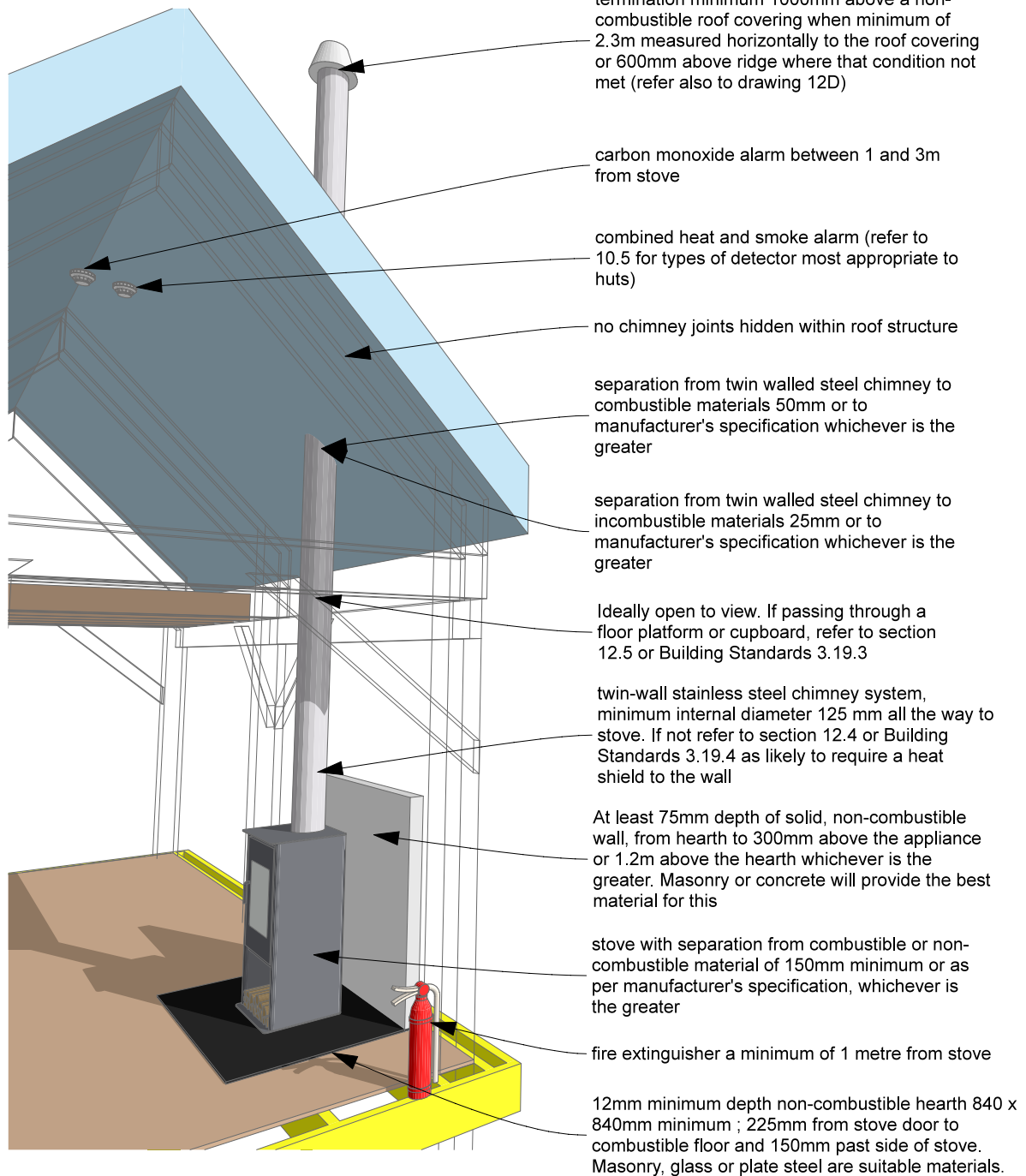

Conditions:

The exterior covering is non-combustible

The flue is an insulated twin wall metal type from top of stove to terminal

The stove is designed to run with the door closed

In any other situations refer to Building Standards 3.19 for suitable details

12A

12.1 General

This guide relates only to solid fuel stoves designed to burn wood, coal and peat in any combination, and their installation. It does not deal with any type of gas, oil, pellet or wood chip stoves as these are not generally compatible with low impact, low carbon hutting principles and registered installers should be used.

You are strongly advised to draw a section and plan of your solid fuel stove installation in order to design the whole installation correctly and identify any specific safety issues. This will also help you to quantify and specify the several parts you will require.

12.2 Manufacturers' instructions

Always refer to stove and flue manufacturer's own instructions. Stove manufacturers provide instructions on safe distances from side and back of appliance (including the flue) to combustible materials as well as for controlling hearth temperatures. This Guide does not cover stoves for whom manufacturers' data is not available, stoves that have been modified or stoves that are home-made which are strongly discouraged. Note that the Building Standards (and guidance herein) may sometimes appear more onerous than manufacturer's instructions and in these instances you should follow the former.

12.3 Hearths

Many modern solid fuel stoves are raised off the floor by legs and guarantee a hearth temperature under the stove less than 100°C. This is the recommended type and the only type that this Guide covers. The stove manufacturer's instructions should confirm this, amongst other important specifications, including minimum distances from the stove to walls, soft furnishings etc. Always consult these details very carefully and incorporate them early on into your design.

Whatever type of stove, a hearth must be provided made of completely non-combustible material, measuring at least 840 x 840 mm, extending at least 225 mm in front of the stove door (300 mm if can be used open) and 150 mm to either side. Follow the diagram (figure 12B), which is the same as in the Domestic Building Standards (Section 3.19.5). If the floor is tiled with ceramic or stone with a thickness of at least 12 mm and fully grouted to the areas in figure 12B then it is not necessary to install an additional hearth.

Suitable materials for a thin hearth of 12mm minimum thickness are steel or toughened glass and the latter can be purchased already shaped and toughened for this specific purpose.. Alternatively a concrete hearth (inevitably > 12mm depth) could be cast in situ and tiled or not. This is often done within a plywood shutter leaving the ply base in the floor permanently. All these hearth types may only be used where the stove is guaranteed by manufacturer to give a hearth temperature of less than 100°C

Plan of Appliance on a Hearth

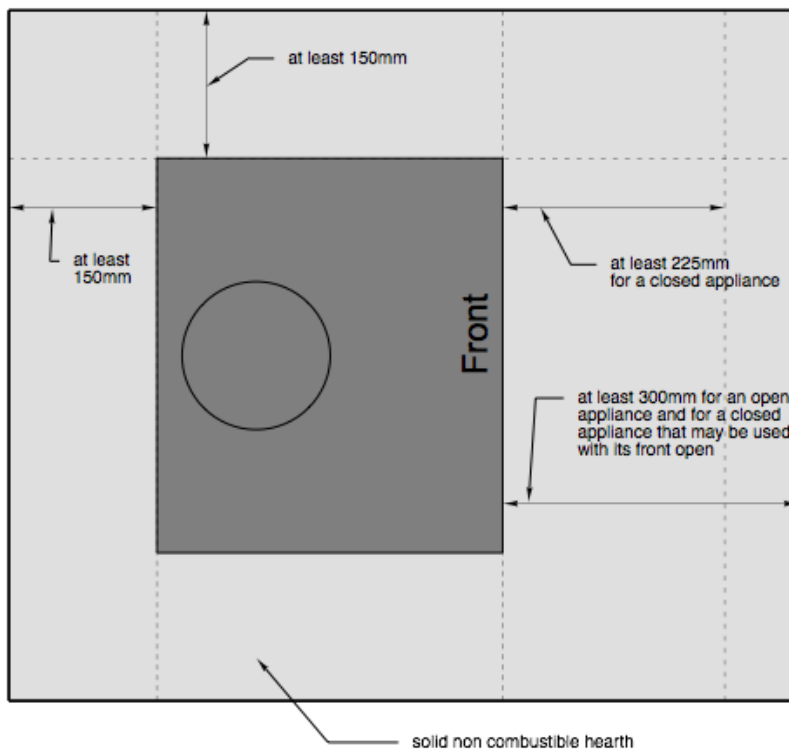

Or as manufacturers instructions

12B

12.4 Separation from combustible and non-combustible surfaces

Neither the sides nor the back of a stove should ever be closer than 150mm to non-combustible surfaces. Separation to combustible surfaces and furnishings will be greater than 150mm and the manufacturer's specification should be closely followed.

A combustible surface between 150 and 300mm from the side or back of a stove will require heat protection and this should be provided by 75 mm minimum of non-combustible material such as stone or concrete between stove and combustible wall. This protection should extend up the wall at least 300mm above the appliance or 1.2m above the hearth, whichever is the greater.

To provide heat protection from any un-insulated section of stove pipe (flue-pipe) - the maximum length of a vertical un-insulated flue-pipe is 1200 mm above the top of the stove - a non-combustible heat shield is required to extend above the height of the flue (refer figure 12C). This could be a continuation of the 75mm non-combustible material or a heat shield of non-combustible material such as steel or glass with an air gap of 12 mm between it and the wall. It may therefore be simplest and safest to install an insulated chimney all the way to the stove itself.

Proximity of flue to combustible materials

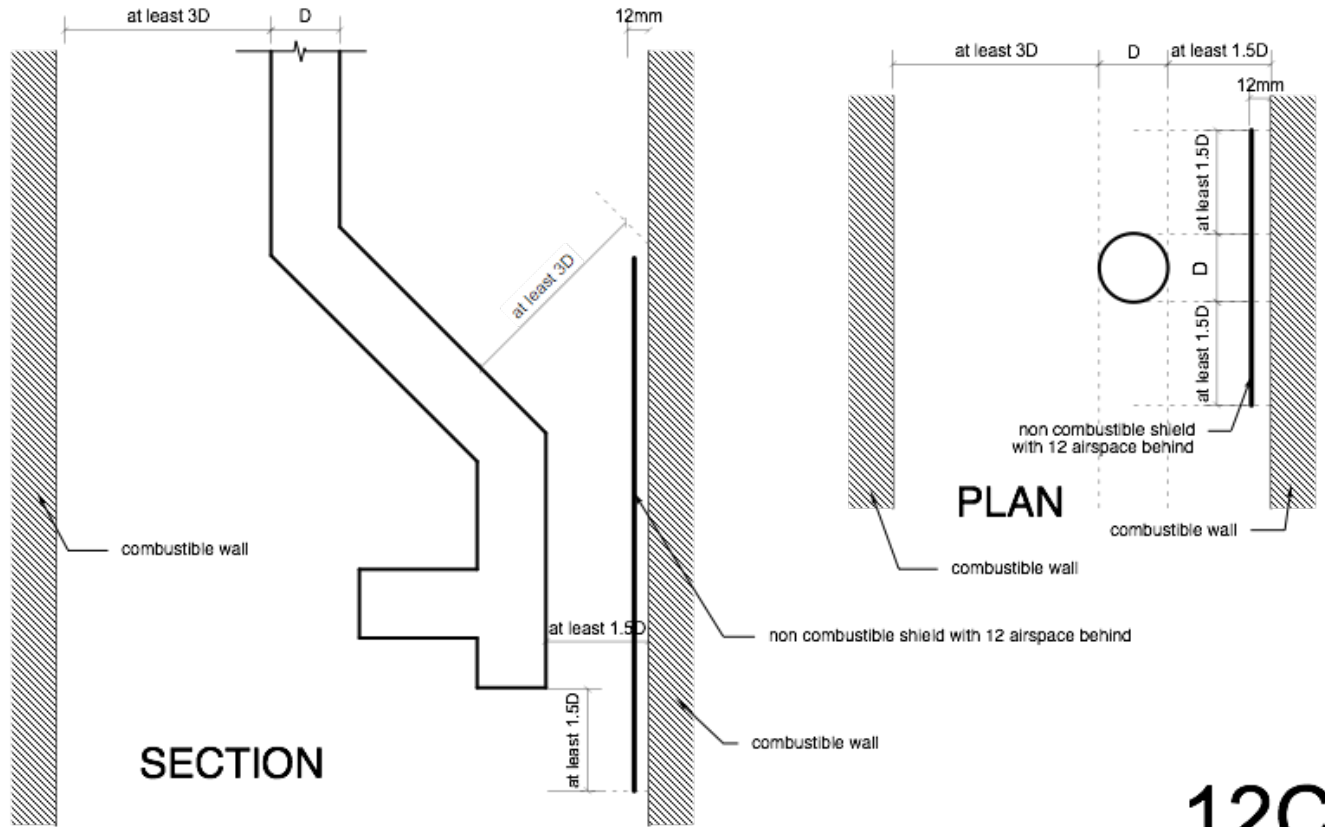

Plan and section of flue showing back plates

12C

12.5 Flues and Chimneys

The following does not refer to masonry chimneys of any type, whether hand built or other systems. It is traditional in many Scandinavian huts for instance to build such masonry chimneys founded on the ground itself within a timber structure. This is an excellent strategy to reduce fire risk but is beyond the scope of this Guide. If you choose this route you will need to follow the domestic Guidance for masonry chimneys (Sections 3.19 and 3.20 in the Scottish Building Standards). In Scottish huts, most chimney systems are expected to be metal and it is these therefore to which this Guide is addressed.

A twin-walled, insulated flue/chimney may be fitted from immediately above the top plate of the stove all the way to its termination above the roof. Alternatively a short (1200 mm max) uninsulated section may be installed immediately above the stove connected to the insulated flue above.

Flues are safest, most efficient and most economic when fitted into the top of the stove and travel vertically all the way up and out of the building. In this way the hut can benefit from the heat escaping from the stovepipe wall. Alternatively the flue may depart from the back of a stove for a horizontal distance of not more than 150 mm before bending 45 degrees or 90 degrees up an external wall. This does allow for a soot trap or inspection plate at the bend. (A vertical flue has to

be swept down into the stove).

The correct separation between proprietary twin-walled insulated chimneys and any combustible material is given by the manufacturer and is often 50 mm but this should be carefully checked. That separation is maintained by proprietary support bands that are fixed to walls either internally or externally. Where a flue passes through a wall, platform floor, roof or hidden space such as a cupboard there is significant danger of ignition of adjacent combustible materials and it is essential to follow the flue manufacturer's advice. In hidden spaces you should provide a guard around the flue to ensure that no material can come within 50 mm of the flue by accident.

Where the flue passes through any structure or cupboard, hidden attic etc, ensure that it is held securely in place by proprietary metal rafter support brackets or similar giving the required minimum separation and insulation from any combustible material.

Ideally the flue will be left as open and visible as possible. Consider this at an early stage of hut design. Do not take it through a platform floor or any other hidden space (such as a cupboard) unless it is really necessary. Ensure that there are no joints in the flue where an insulated flue has to pass through any structure. You will find it helpful to draw a section and plan the lengths of flue to be installed.

It is essential to ensure that the structural hole (in a roof or floor platform) for a flue is slightly oversized so that it can accommodate a fireproof lining of a proprietary non-combustible material that meets the Class 0 standard in the Building Regulations.

The flue/chimney will be sealed to the roof covering with a non-combustible flashing either of the fireproof rubber type or a malleable metal type. In an insulated structure it will also be necessary to dress the waterproof roof membrane onto a metal separating plate fixed to the upper surface of the insulated roof structure. This is assuming the roof has been built correctly with a ventilated cavity between the insulated roof and the roof covering.

The height of the flue termination above the roof and ridge is shown in figure 12D. In many cases the flue will need to terminate a minimum of 600 mm above the hut ridge. But note that many manufacturers suggest a minimum overall flue and chimney height of 4.0 metres to achieve a satisfactory draught. In low, single storey huts this may mean extending the flue well above 600 mm of the ridge and, in these cases, you will need to stay the chimney well. There are proprietary systems for doing this or you may design metal structures or wires to achieve the stability required. Any movement, including long term vibration in a metal chimney will cause seals to break and allow precipitation and /or combustion gases to leak into the building.

All commentary in 12.5 is based on non-combustible roof covering. For combustible roof covering a flue outlet should be 1.8 metres above roof finish.

Position of flue outlets

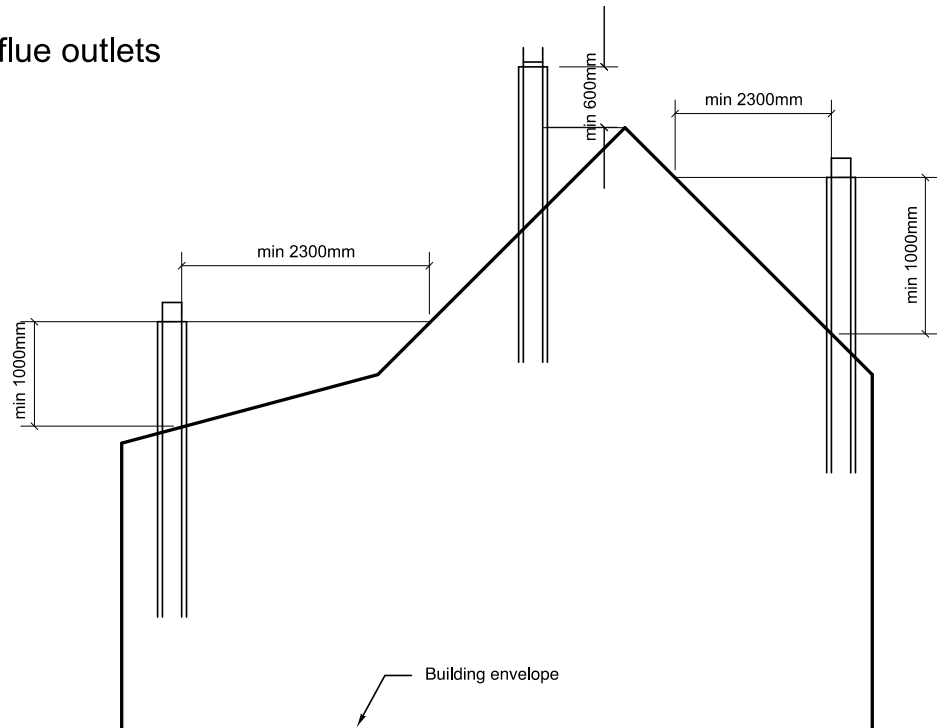

Flue outlets in huts with more steeply pitched roofs will have taller flues because of the proximity of the weather skin and may well require stays unless they are near the ridge

Flue terminal must also be more than 1000mm above any opening rooflight within 2300mm horizontally

For combustible roofs the dimension 1000 should be increased to 1800mm

12D

12.6 Air supply

Combustion requires an adequate air supply and the stove will not operate efficiently without one. Furthermore it can produce toxic gases if inadequately supplied creating a severe danger to inhabitants (even a danger of death) and damage to the environment. A small, insulated hut space requires careful consideration as it may be sealed sufficiently well to restrict the combustion air available.

If the stove output is rated at 5kW or less it will be necessary to add up the fixed ventilation area (that is, permanent, unclosable ventilation openings) in the space occupied by the stove and ensure that it totals at least 12000 sq mm. This can be provided by slotted ventilators of a permanently open type. However, good practice is to provide a direct air supply from the exterior environment into the stove. This is generally achieved by use of a proprietary air supply kit supplied by the stove manufacturer. The pipe for this kit can be installed either through the wall or the floor of the cabin if the space under the building is well ventilated and open to the external environment. Stoves with output of over 5kW are not recommended in huts (unless heating water in a back boiler - see 12.8) but where they are installed good practice will again require provision of a direct air supply into the appliance.

In such a small space as an insulated, reasonably well-sealed hut, an extractor fan may cause a problem to the proper functioning of an open-flued solid fuel stove by reducing air pressure. This Guide therefore strongly recommends that extractor fans are never installed in huts with stoves even in separate bathrooms and toilets. Rather ensure that there is an openable window or fixed

ventilator to clear unwanted odours and any moisture generated. Good practice is to carry out a spillage test on completion of installation.

12.7 Fuel

Ensure your wood is properly air dried as burning wet wood or wet peat is inefficient, pollutes the environment and may damage your stove and flue in the long term. Store it in a well ventilated and covered space outside the hut.

12.8 Stoves with boilers

Stoves with internal boilers present particular hazards and these are detailed in Section 16 on washing and showering. The main concern with boilers is their ability to boil water when the stove is run too hard or the water supply is inadvertently interrupted as can occur where a private supply is not entirely reliable. This can pose a significant danger to inhabitants. There must be provision to let pressure and steam escape safely from an overheating system (ie they should be fully vented to the outside of the hut). Systems should be designed so as not to overheat and may include 'heat dumps' to achieve this. Take professional advice if you are not entirely confident in your installation.

12.9 Safety precautions

Section 10 details **good** practice in fire safety precautions which should be followed in all huts but with particular care where a stove is installed. Make sure that as a minimum you have fire extinguishers both inside and outside the hut, a smoke and a heat alarm within the hut as well as a carbon monoxide detector in every room containing a combustion appliance and any that could be used for sleeping. These must be sited and maintained according to the manufacturers' recommendations.

If you are off mains then you must have spare batteries for your alarms and replace them as soon as indicated by the low power indicator on the alarm. Assuming the hut will be used by different parties, some of whom may have little or no experience of operating stoves, it will be essential to provide well displayed safe operating instructions along with the fire safety drill and emergency procedures.

13. Cooking and Food Storage

13.1 Cooking outside

Only the simplest of huts will not have facilities for preparation of hot food. Huts in summer use may just be used for living and sleeping accommodation with food preparation outside. This has benefits in terms of providing adequate ventilation and avoiding fire risk. An overhang or awning could provide some shelter and an open pit fire or barbeque arrangement could be formalised as part of the hut garden.

13.2 Cooking facilities

As the hut is most likely to be off grid, it is not expected that cooking by electric stove or microwave will be possible. The use of camping stoves, propane bottle stoves or wood stoves (see Section 12) are alternatives. All require careful thought regarding working area, safe use, fuel storage and ventilation. A barbeque, even a small disposable type, should never be used indoors and should

not be brought indoors when outside cooking is complete. Even though there may be no visible flames if the coals are still hot, or even just warm, the combustion process will still be taking place producing life threatening carbon monoxide.

13.3 Camping stoves

Being portable these might be used inside and out. Inside the hut it would be sensible to provide a worktop so the stove can be operated from the standing position. It should have a washable non-combustible surface including an upstand when positioned against a wall of at least 300 mm. Provide ventilation to the room when the stove is being used (see 13.6 below).

13.4 Propane stoves

These vary in size from simple ring burners, needing a worktop to sit on, to full freestanding stoves with gas ovens. They should be fixed down so they cannot move when in use. Fuel storage should be outside and not under the hut. It should be easy to isolate the gas supply both inside and outside the hut. Provide ventilation to the room when the stove is being used (see 13.6 below).

13.5 Safety

Gas systems can cause explosion or asphyxiation. For this reason the installation, servicing, maintenance, repair and removal of systems should be carried out by registered "Gas Safe" engineers.

13.6 Ventilation

If any cooking is carried out within the hut, including the use of portable stoves, adequate ventilation must be provided. This is covered in Section 9 windows and doors. Special attention should also be given to provision of alarms and detection devices. Note that a carbon monoxide detector is mandatory in a hut which may be used for sleeping whether a cooking appliance or stove is installed or not. Barbeques should never be used indoors. (see 13.2)

13.7 Food storage

Some place for food storage will be required. This will include dry goods, tins and bottles not requiring temperature control or other food needing to be kept cool. Both will require cupboards that are cleanable and secure from vermin. A cool space can be achieved by forming a traditional larder that is probably on the north side of the hut, outside the insulation envelope and with some thermal mass such as stone shelves if possible. High and low level ventilators to the external air will allow the ambient temperature of the hut location to provide a suitable cooling effect and will also remove moisture. Due diligence will be required to ensure food remains fresh. An alternative is to have a small fridge run by gas or electricity, the latter perhaps having a photovoltaic supply.

14. Water and washing

Any wastewater disposal system serving a hut will require a Building Warrant. It may also require SEPA consent (see Section 15 on waste disposal).

14.1 Need for water

A hut where people stay overnight will need a supply of water. This can either be carried to the hut or installed as a piped supply. It may be manageable to carry wholesome water in if only for drinking and cooking at a hut of occasional use, when combined with a composting toilet and rain water for washing. Collection of rainwater from the roof allows autonomy from supplies and would be considered good practice. Rainwater is not wholesome water and will require treatment to be potable. Rainwater can be used for bathing and washing up.

It is recommended that we drink 2-3 litres of water per person per day with as much again used in cooking. This rises to 15 litres for bathing and clothes washing and 50 litres if water borne sanitation is required, (see Section 15).

If a supply is wanted and if a hut is not able to connect to the public supply then a private supply must be found. Any of these options should be combined with good water conservation management so the hut is sustainable with minimum use of resources.

14.2 Private water supplies

The owner(s) of the hut (or the landlord, depending on the tenancy agreement) will be responsible for the maintenance of a water supply. The quality of the water from private supplies is highly variable and when poor can cause health problems. The sources of private water supplies also vary, including surface water such as burns and rivers as well as private impoundment reservoirs, groundwater such as wells and boreholes or springs where groundwater issues naturally at the surface from an aquifer. Any water supply will comprise a source leading to a filter to remove suspended solids, leading to storage (where volume will depend on the reliability and seasonality of the supply), leading to a treatment device, leading to a tap.

14.3 Surface, spring and groundwater sources

A burn in close proximity and higher up than the hut may be a suitable source from which to capture a supply by putting in a pipe. This must be securely fixed down below the year-round water level and be fitted with a good inlet strainer. Ideally this should be in a natural pool with minimum intervention. If you need to construct a dam it will be necessary to contact the Scottish Environmental Protection Agency (SEPA).

If a spring is found local to, and higher than, the hut it may be possible to pipe it. The vicinity of the spring should be fenced to exclude farm and wild animals from contaminating the supply.

Taking water from the ground can have benefits in that it will be less likely to have sediments and living organisms in it. One method is to sink a borehole, which must seek water-porous rock. The cost of this is only likely to be justifiable in the case of multi-hut developments.

14.4 Water point

Private water supplies may need a wayleave if coming from adjacent landowners and would require treatment if used for drinking. A standpipe could be placed outside the hut or the pipe could be run to plumbing inside the hut. In this case it should have a non-return valve and an isolation tap where it enters the hut. To prevent freezing any exposed pipe work should be insulated below the hut and the supply buried at a minimum depth of 750 mm. A water toby outside the hut would allow the hut to be switched off when not in use, and in addition, the plumbing system should be drainable with a scour pipe at the low point.

14.5 Washing up and washing

Washing up and washing can be achieved with minimal water use and do not necessarily lead to waste water disposal systems which would require Building Warrant. Above ground containment and composting systems using biological filters can be designed and the specialist literature on this subject should be consulted.

14.6 Water quality, treatment and legal responsibilities

Water quality will depend on the cleanliness of the source, the effectiveness of the filters and the installation of the tank and pipework. In Scotland it is a duty of the Environmental Health Department of the Local Authority to test all private water supplies. Water in Scotland is tested for 51 substances or parameters. The 10 key parameters are Coliforms, *E.Coli*, colour, turbidity, acidity(pH), Aluminium, Iron, Manganese, Lead and Trihalomethanes. Some, like the bacteria parameters, are a health risk. Yet others are aesthetic, arise from treatments at public water works or arise from old pipes. If a test reveals improvements are necessary then measures such as ceramic filters or UV treatment will be required. These units can be located beneath the sink within the hut. UV will require an electric supply.

Where pipework is standardised to blue MDPE pipe and plastic water storage tanks are used, the hut owner should not be faced with many problems especially if the source is well chosen. If collecting rainwater from a roof it should be noted that some materials including gutters, downpipes and containers can potentially contaminate the water for drinking purposes. Whilst clean un-corroded steel or UPVC rain gear should not contaminate rainwater, it will be best to only store potable supplies in UPVC and to flush out regularly.

KEY REFERENCES.

1. *Choosing ecological water supply and treatment* by Judith Thornton, CAT publications.
 2. *CIRIA C539 rainwater and grey water use in buildings: best practice guidance*,
 3. *WRAS Information and guidance notes* No. 9-02-04 and 9-02-05
- Useful link: www.gov.scot/Topics/Environment/Water/17670/pws

15. Waste and Composting Toilets (MANDATORY IN PARTS)

Any wastewater disposal system serving a hut will be deemed an Exception to Type 23A and therefore will be subject to Building Warrant. In some circumstances it might also require SEPA consent. Compost toilets should not require a Building Warrant as long as certain conditions are met (see 15.5 below).

Choice of sewage system

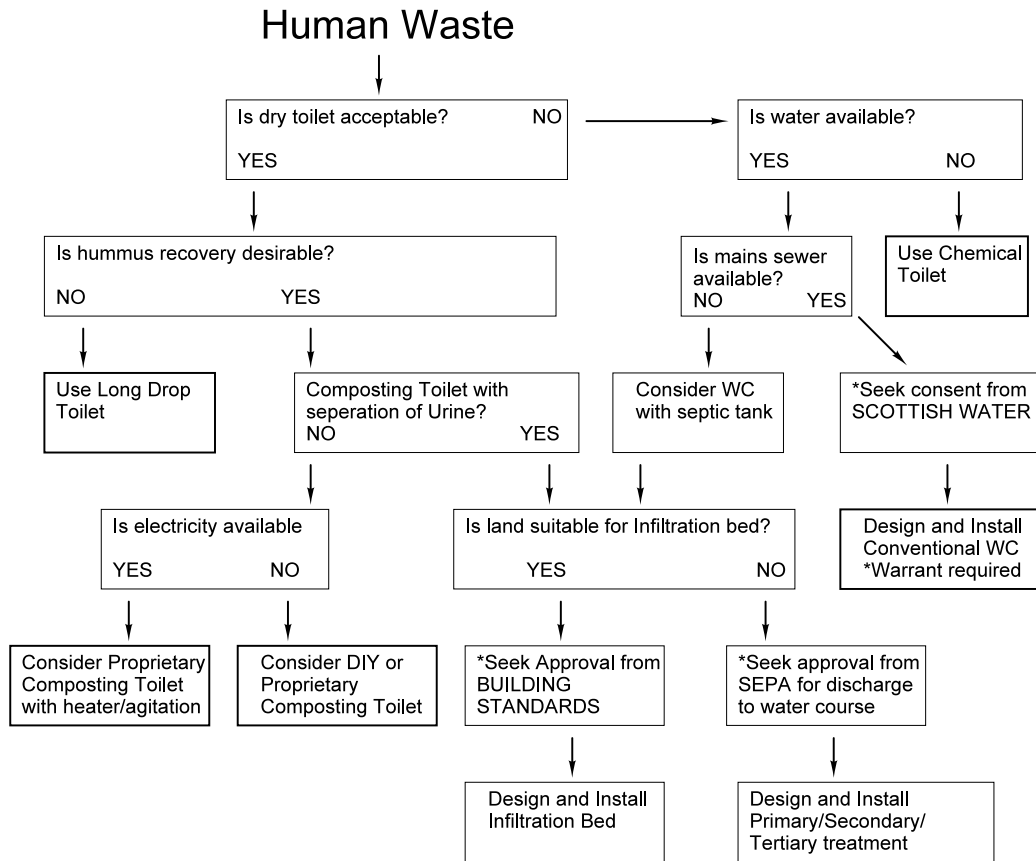

15A

** Separate approval from this guidance is required*

Note any discharge of waste water to a water course requires consultation with SEPA

If urine is contained and removed from site no infiltration bed is needed

15.1 Need for waste management

The builder of any hut where people will stay overnight will need to consider waste treatment. Multi-use hut developments will almost certainly have shared waste water disposal systems which may involve septic tanks and tertiary treatment such as reed beds. All such systems may need

SEPA approvals and will need a Building Warrant. **Good** practice for single or well dispersed huts is the use of dry or composting toilets, which fulfil the objective of low impact on the land and minimal servicing. There may be grey water from cooking and urine separation from some types of compost toilet, and these can be dealt with by a simple soakaway (infiltration bed) if soils are suitable (see 15.6 below).

15.2 Grey Water (MANDATORY SECTION)

Grey water is waste water from washing and washing up which can be easily and safely disposed of in relatively simple infiltration beds in many rural sites with suitable ground conditions. Grey water can be led away by pipework above or below ground to a soakaway which will be designed according to Building Standards **and will require a Building Warrant** (see 15.6 below).

15.3 Sewage Treatment - options (SOME ARE MANDATORY)

Human sewage can be dealt with by water closet, chemical closet or earth closet/compost toilet (see definition below). Water closets will be familiar to everyone and rely on a piped water supply. The waste is taken to a septic tank or a self-contained treatment plant (requiring a power supply for aeration), the effluent from which is led to a soakaway and/or further treatment such as a reed bed or wetland. Such systems are widespread in rural areas of Scotland, are effectively autonomous and so fit within the definition of a hut. **They always require a Building Warrant and possibly approval from SEPA. In any case you need to register a septic tank location with SEPA. This incurs a small charge.**

Two further important points to remember when choosing a septic tanks: they should be emptied at intervals and this is usually done by lorry pumping unit; they need more or less continuous use to keep the bacterial process going. The infrastructure investment is relatively large in relation to a single hut. If a group of huts is planned then a shared facility will be the best option. There is an added advantage that the grey water can be directed into the septic tank too (see Section 15.2).

Chemical closets involve a toilet connected to a removable or pumpable storage container that is taken away at regular intervals. This system although prevalent on caravan sites is not thought appropriate for hut sites which are more remote and require a simpler more environmentally sensitive option. However the chemical closet does not utilize a wastewater system and does not therefore require Building Warrant.

This good practice guide considers that waterless earth closets - generally now known as composting toilets or dry toilets - are more appropriate for huts as they are lower cost, need no water supply and are more easily removable. Earth closets or composting toilets can be installed inside huts or in separate ancillary structures.

15.4 Composting toilet - definition

A self-contained unit for the biological treatment of the products of human excretion which does not use water and does not require a wastewater disposal system. It may utilise above ground composting facilities separate from the collection unit itself (toilet) for onward composting over an extended timespan allowing the eventual use of the compost in non-food applications. Such facilities should be contained, rodent proof and well managed, in accordance with Good Practice (see references below).

15.5 Composting toilets - variants

They are characterised by not using any water - hence another frequent name “dry toilet”.

A compost toilet must not utilise a ‘wastewater disposal system’ if it is to be exempt from the requirement for a Building Warrant. It follows that the composting toilet must be self-contained in the sense that all waste is contained and can be removed from the site, utilised or broken down without entering an underground disposal system. Sophisticated systems - more usual in houses - compost the solids in a tank often ‘agitating’ the compost mechanically and evaporate off the liquids, sometimes with fans and/or heaters. Such systems need an electrical supply and are perhaps not therefore appropriate for huts but are in use for communal toilets in some remote locations in Scotland.

A simpler system has a containment of the waste below the seat, a natural bulking and drying agent - usually sawdust or straw - which is thrown into the toilet after each use, and a ventilation pipe to dry the liquids. Often these toilets are built with double chambers with the seat swapped to allow the solids to compost for a year or more in situ before removal.

Because urine can be a source of smell and there is a risk that the process becomes anerobic, composting toilets are often designed to separate the urine from the solids. An example of this is shown in figure 15C. The solids are contained for off-site disposal or for above ground composting in bins of one sort or another. Urine is lead away to above-ground containers which can be disposed of off site or emptied onto compost heaps as part of properly managed composting of biological waste where it can contribute valuable nutrients to the eventual compost. This guide does not describe the many different designs for above-ground composting of waste and hutters should consult the extensive literature on the subject.

None of the above systems should require a Building Warrant. However this will depend on individual circumstances. If in doubt seek advice from a professional such as an architect

15.6 Soakaways: also known as infiltration beds (MANDATORY)

Urine can also be lead into small soakaways below ground and diluted with grey water from cooking and washing. A soakaway will usually require a Building Warrant as may be deemed a ‘wastewater disposal system’.

The suitability of the soil is established by a percolation test. The results of this can also determine the size of the soakaway. It will be necessary also to dig a deeper hole to establish the level of the water table if any. Guidance on these procedures is available in the *Building Standards Technical Handbook*.

Infiltration Bed

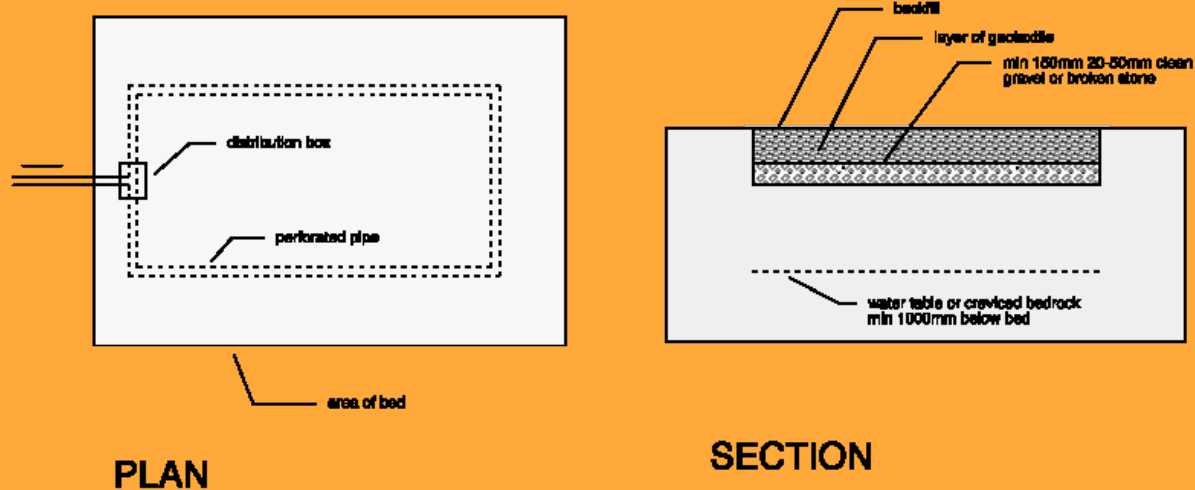

Connect waste pipe to distribution box with 110mm diameter solid plastic pipe

15B

15.7 Pit latrines

More basic forms of compost toilet include the pit latrine or long drop. Such toilets involve digging a hole over which the toilet is located. When full, the building is moved to a new site. Such facilities may be appropriate in remoter mountain bothies with intermittent use.

15.8 Location of facilities

If you install a composting toilet in a building separate from your hut, according to the new rules, it should be no closer than 6m from your hut and any official boundary, and 6m from any other building including another hut. Alternatively, it could be installed within a lean-to or within the hut. However, in that case, it would be included in the 30 m² maximum area. A small, separate building can be built without the need for a building warrant providing that it meets Type 13 of Schedule 1 of the building regulations i.e. less than 8m² and more than 1m from the boundary

Note at the earliest stage in hut planning that all septic tanks and treatment plants must be a minimum of 5 metres from huts and boundaries and that infiltration beds must be at least 10 metres horizontally from water courses or permeable drains and 50 metres from a spring, well or borehole. They will also require emptying and that can be done by tanker if there is a roadway within 25 metres of the tank.

KEY REFERENCES

1: *Good Building Guide 42* Reed Beds and Mound Soakaways BRE

2: *Sewage Solutions* by Nick Grant, Mark Moodie and Chris Weedon CAT Publications

Composting Toilet

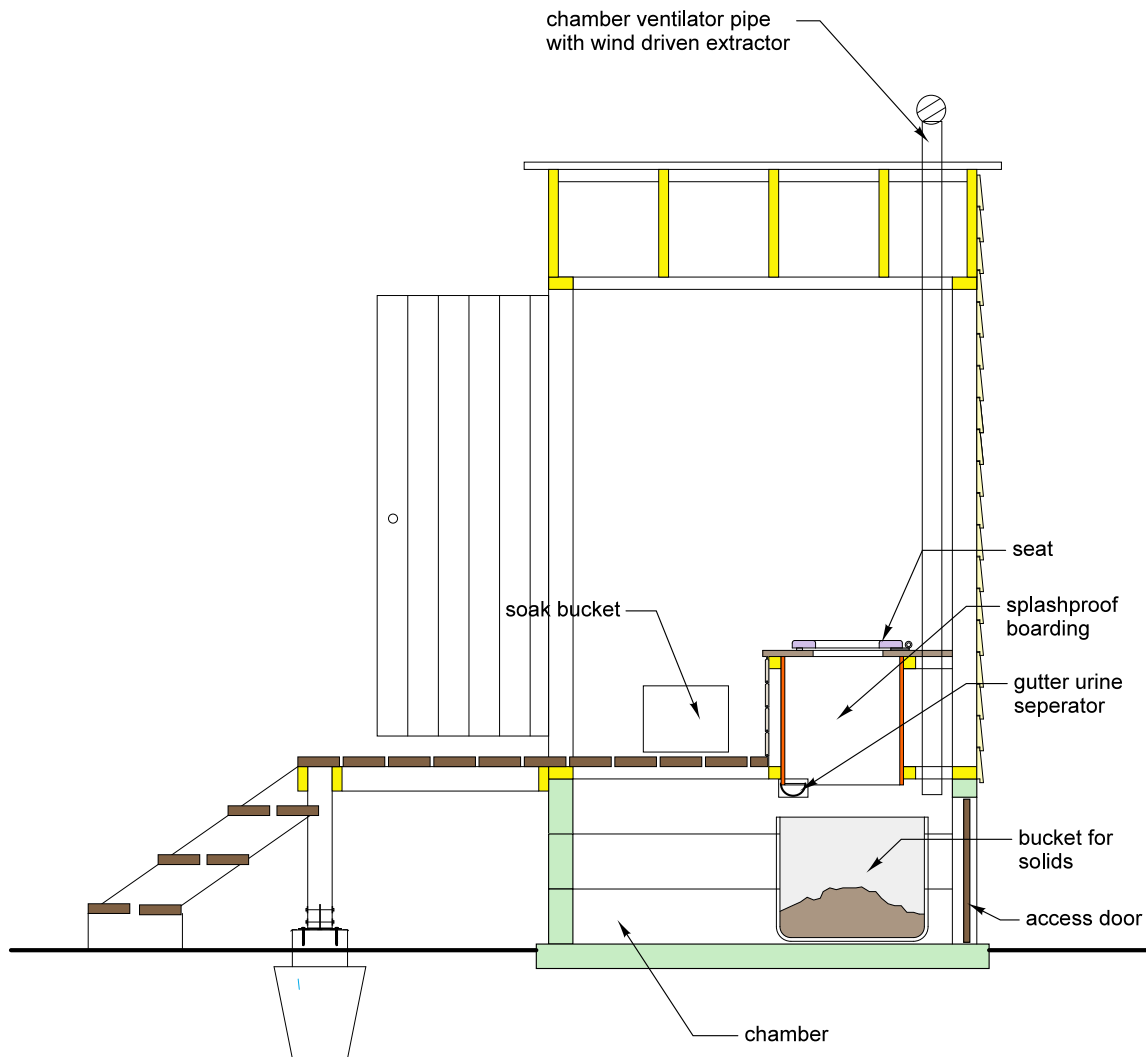

*Simple DIY building showing main features
Chamber could be built in block work or timber provided
it is dark and reasonably tight against invasion by wildlife*

15C

16. Electrics and Photovoltaics

16.1 Off grid

The principles of simplicity and low impact suggest that the majority of huts will not be connected to the national electricity grid. Power can be carried into the site using batteries ranging from hand-held torches to larger (typically 12V) storage batteries plugged into a lighting system. You may also use inverters in combined units to give 240V AC. Where budgets permit, micro-renewable systems will be the ideal sustainable solution for single huts. For multi-hut developments requiring power - which are not covered in this Guide - renewable systems with shared power sources whether wind turbines, hydro power and photovoltaic panels (PV) will be **good practice**.

16.2 Photovoltaic panels

For individual huts with a suitable roof or piece of adjacent open ground, suitably orientated PV panels offer an ideal low carbon, low impact power solution. DC systems (12V) with or without inverters to supply 240V AC can be installed according to individual needs. Battery banks are usually required (see 18.3). The wind uplift on your panels can be very significant depending on the exposure of your site and you are advised to take professional advice on suitable mountings and fixings. Roof penetrations also need to be carefully sealed and this will be determined by the type of roof covering. Stoves and gas cookers are best suited to heating and cooking (see Section 12).

16.3 Safety

Both AC and DC systems can threaten life. Best practice will therefore be to use professional installers. Standards for sizing of wires, containment, location of sockets, earthing systems, overload trips and isolation must be properly specified. Whilst DIY installation is possible, the installer will be responsible for the safety of the system. **Any installation should be checked, tested and certified by a qualified electrician who is a member of SELECT or another trade organisation.**

The recharging of some batteries leads to the emission of flammable gases. For this reason a charging space that is adequately ventilated and sealed off from the rest of the hut must be provided.

17. GLOSSARY

Bay - Any division of a building between vertical lines or planes, such as between two adjacent supports.

Beam - A horizontal structural element spanning an opening and carrying a lateral load.

Bent - A structural framework, transverse to the length of a structure, designed to carry lateral as well as vertical loads.

Ceiling tie - the horizontal tie spanning a space and preventing the roof structure from spreading against the walls.

Cripple stud - a stud located either above or below a framed opening that does not run the full height of the wall.

Dwangs - horizontal bracing piece used between wall studs or floor joists to give rigidity to the wall or floor frames of a building.

Elevation - Architects often use the word elevation as a synonym for façade, so the north elevation is literally the north-facing wall of the building.

Girt - a horizontal structural member in a framed wall.

Header joist - A beam or timber positioned horizontally between two longer beams so as to support the ends of tailpieces or to accept common joists.

Joist - one of a series of horizontal members supporting a ceiling or floor.

Lintel - a structural horizontal block that spans the space or opening between two vertical supports.

Plan - a horizontal section through an object.

Plate - A plate or wall plate is a horizontal, structural, load-bearing member in wooden building framing.

Post - A post is a main vertical or leaning support in a structure.

Purlin - Purlin plates are beams which support the mid-span of rafters and are supported by posts.

Rafter - A rafter is one of a series of sloped structural members that extend from the ridge or hip to the wall plate, downslope perimeter or eave, and that are designed to support the roof deck and its associated loads.

Ridge beam - A ridge beam is a structural member used to support the ends of the rafters at the ridge, transferring it's loads to posts or gable end walls.

Section - A section is a vertical slice through a building with one half removed so it is possible to see inside.

Truss - A truss is a triangulated system of (usually) straight interconnected structural elements

Wall plate - A horizontal timber situated along the top of a wall at the level of the eaves for bearing the ends of joists or rafters.

APPENDICES

APPENDIX ONE : Post and beam hut

APPENDIX TWO : Stud frame hut

APPENDIX THREE : Decks